

CAD FILE:

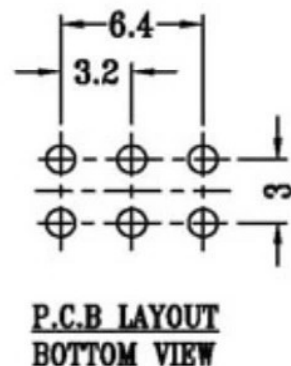
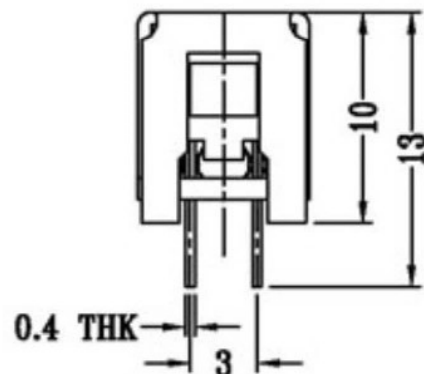
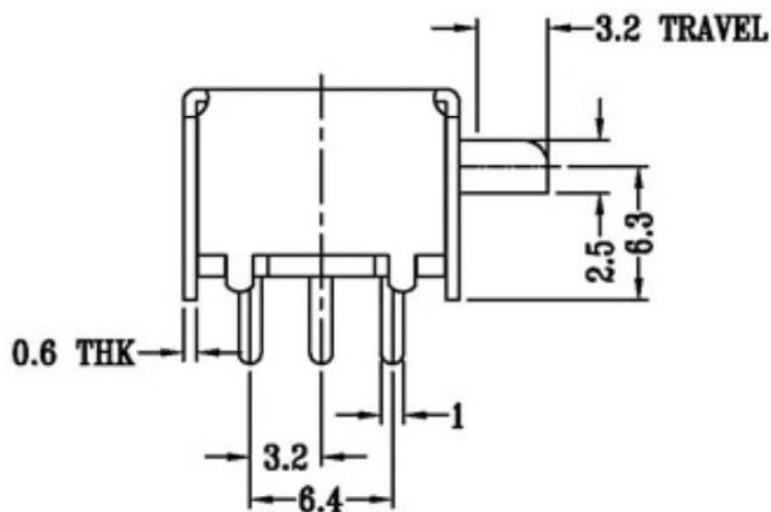
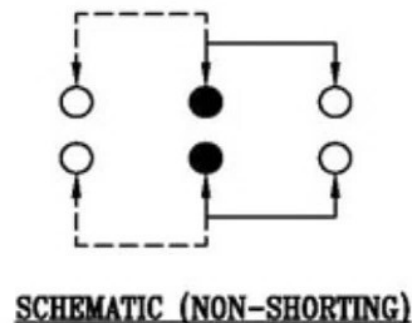
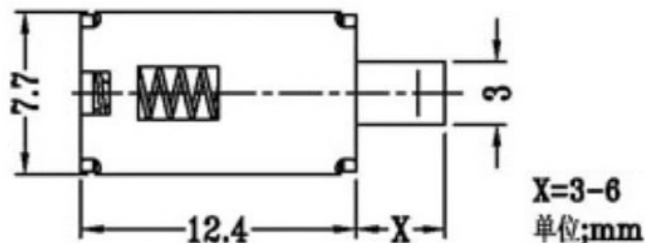

注: "\*"表示关键尺寸(6个)

NO.	PARTS	MATERIALS	Q'TY	FINISHING
9	CONTACT CLIP	PBS C5210R-EH	1	Ag CLAD
8	SPRING PLATE	PBS STRIP	1	Ni PLATED
7	BASE	PHENOLIC RESIN	1	NATURAL
6	TERMINAL	BRASS STRIP	3	Ag PLATED
5	KNOB	PA66	1	BLUE
4	BLOCK	STEEL STRIP	1	Ni PLATED
3	SPRING	STEEL WIRE	1	Ni PLATED
2	CAM STICK	PBS WIRE	1	Ni PLATED
1	FRAME	STEEL STRIP	1	Ni PLATED

TOLERANCE UNLESS SPECIFIED					
WITHIN 1.5mm	: ±0.1mm	A	2012-8-22	初版	
OVER 1.5mm	: ±0.2mm	ISSUE	DATE	DESCRIPTIONS OF REVISION	APPD.
TITLE : PUSH SWITCH			UNIT : mm	DRWG NO.:	
MODEL:			SCALE: 3:1	DWN.	2012-8-22
<b>广东科斯达开关厂</b>				CHK'D	
				APPD.	2012-8-22