

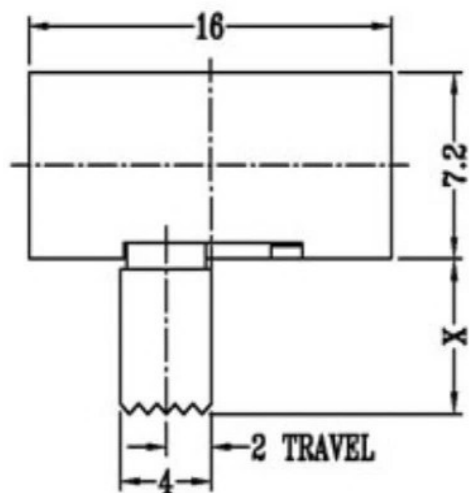

CAD FILE:

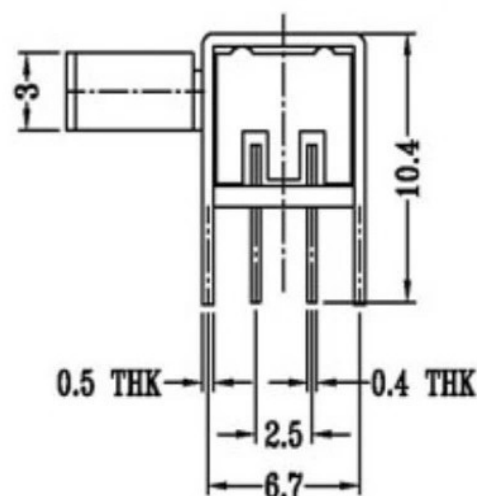

X=3-11
单位: mm

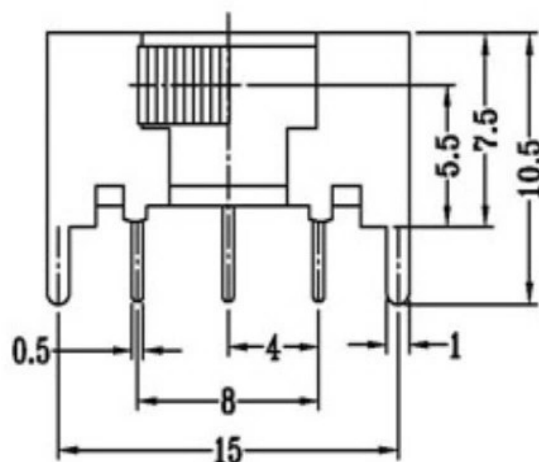
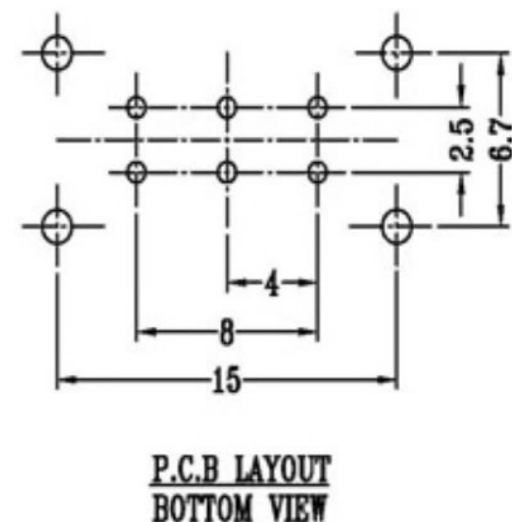
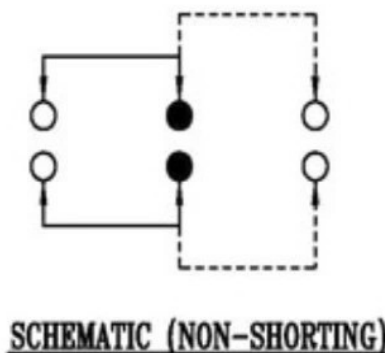

注: "*"表示关键尺寸(6个)

NO.	PARTS	MATERIALS	QTY	FINISH	TOLERANCE UNLESS SPECIFIED	ISSUE	DATE	DESCRIPTIONS OF REVISION	APPD	
8										
7	STEEL BALL	STEEL	1	NATURAL						
6	SPRING	STEEL WIRE	1	NATURAL						
5	CONTACT CLIP	PBS STRIP	2	Ag PLATED		A	2012-12-25	初板		
4	TERMINAL	BRASS STRIP	10	Ag PLATED						
3	BASE	PHENOLIC RESIN	1	BLACK						
2	FRAME	STEEL STRIP	1	Ni PLATED						
1	KNOB	POM	1	BLACK						
					TITLE: HORIZONTAL SLIDE SWITCH		UNIT : mm		DRWG NO.:	
					MODEL:		SCALE: 2:1		DWN	
									2012-12-25	
									CHK'D	
									2012-12-25	
									APPD	
									2012-12-25	

广东科斯达开关厂