

CAD FILE:

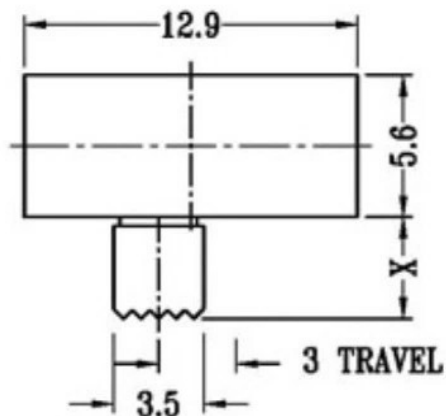

X=2-10  
单位: mm

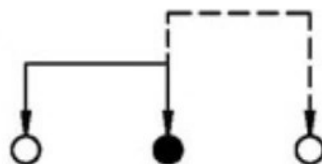

SCHEMATIC (NON-SHORTING)

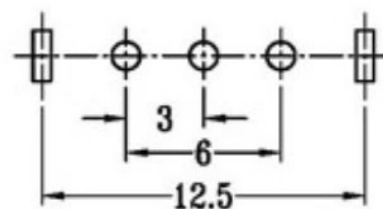
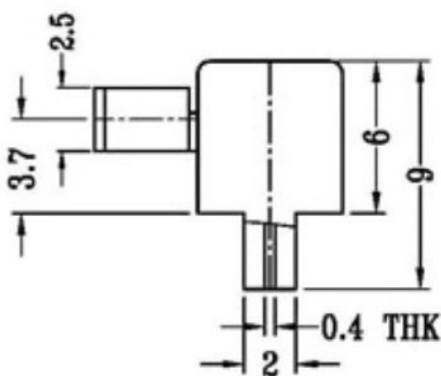
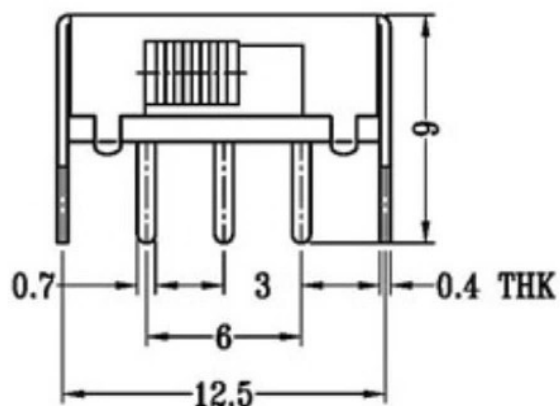

P.C.B LAYOUT  
BOTTOM VIEW

注: "\*"表示关键尺寸(6个)

NO.	PARTS	MATERIALS	QTY	FINISH	TOLERANCE UNLESS SPECIFIED		A		初板		
8					WITHIN		ISSUE	DATE	DESCRIPTIONS OF REVISION		
7	STEEL BALL	STEEL	1	NATURAL	OVER			2012-12-25	APPD		
6	SPRING	STEEL WIRE	1	NATURAL	TITLE: HORIZONTAL SLIDE SWITCH		UNIT : mm		DRWG NO.:		
5	CONTACT CLIP	PBS STRIP	2	Ag PLATED	MODEL:		SCALE: 2:1		DWN	2012-12-25	
4	TERMINAL	BRASS STRIP	10	Ag PLATED	<b>广东科斯达开关厂</b>				CHK'D		
3	BASE	PHENOLIC RESIN	1	BLACK					APPD		2012-12-25
2	FRAME	STEEL STRIP	1	Ni PLATED							
1	KNOB	POM	1	BLACK							