

CAD FILE:

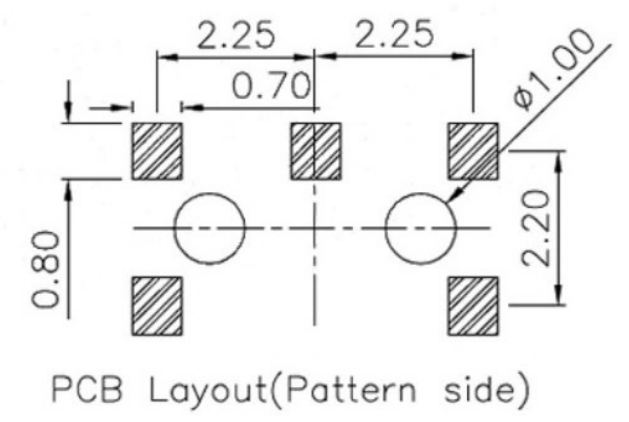
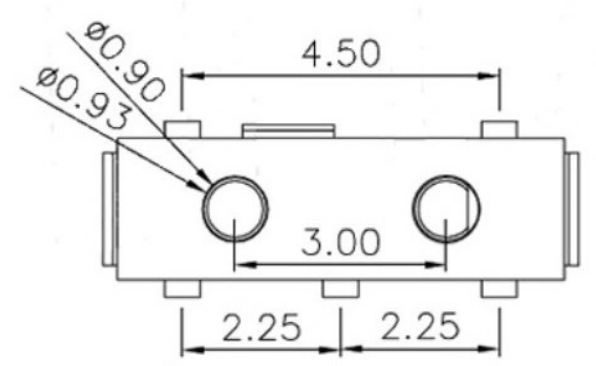
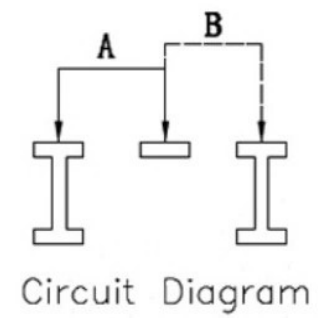
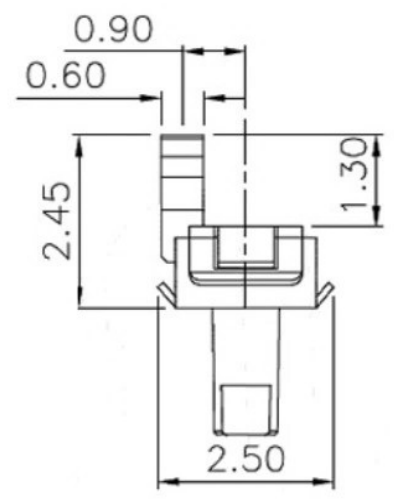
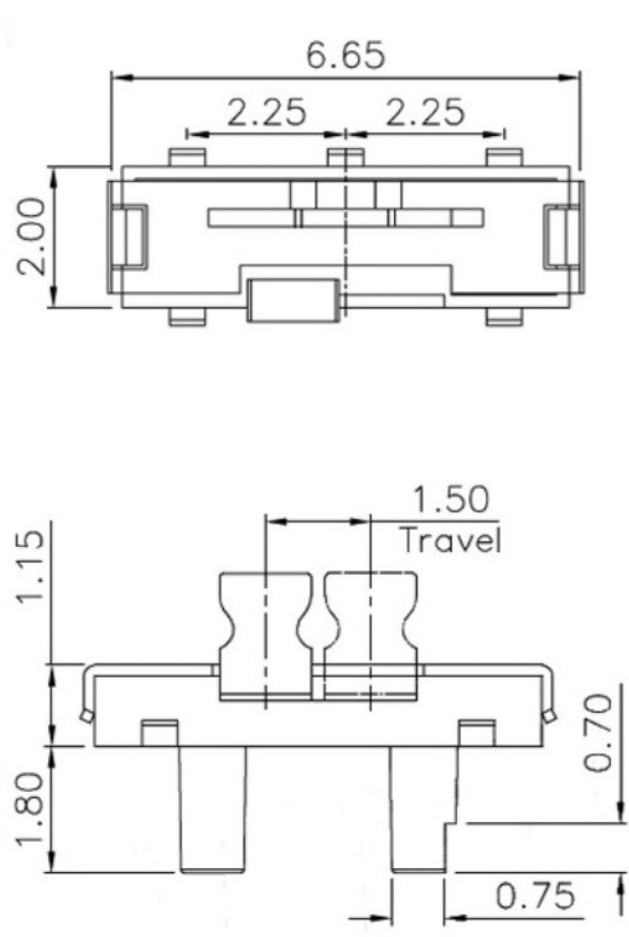

注: "*"表示关键尺寸(6个)

NO.	PARTS	MATERIALS	Q'TY	FINISH	TOLERANCE UNLESS SPECIFIED				
8									
7	STEEL BALL	STEEL	1	NATURAL					
6	SPRING	STEEL WIRE	1	NATURAL					
5	CONTACT CLIP	PBS STRIP	2	Ag PLATED	WITHIN	A	2012-10-26	初版	
4	TERMINAL	BRASS STRIP	8	Ag PLATED	OVER	ISSUE	DATE	DESCRIPTIONS OF REVISION	
3	BASE	PHENOLIC RESIN	1	NATURAL	TITLE : SLIDE SWITCH			UNIT : mm	
2	FRAME	STEEL STRIP	1	Ni PLATED	MODEL:			DRWG NO.:	
1	KNOB	POM	1	BLACK	SCALE: 3:1			DWN.	
					广东科斯达开关厂			2012-10-26	
				CHK'D					2012-10-26
				APPD.					