

CAD FILE:

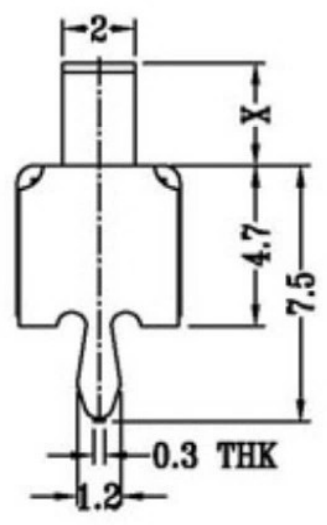
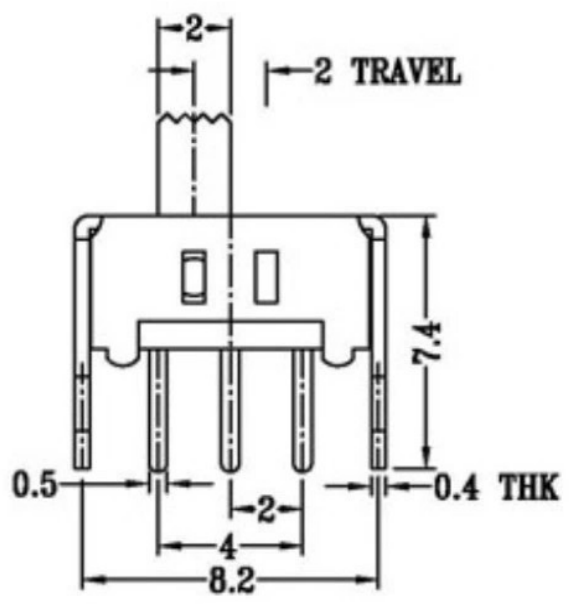
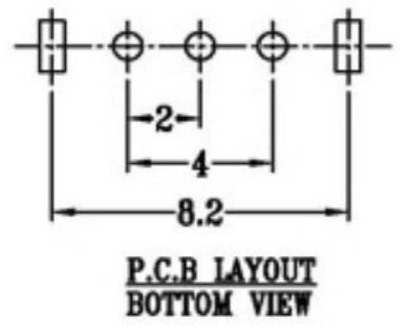
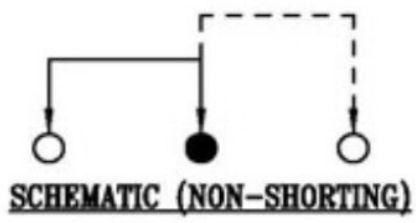
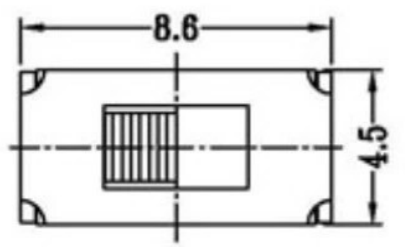

单位: mm
X=2.3.4.5.6.7.8

注: "*"表示关键尺寸(6个)

NO.	PARTS	MATERIALS	Q'TY	FINISH	TOLERANCE UNLESS SPECIFIED				DESCRIPTIONS OF REVISION		APPD.	
8					WITHIN	A	2012-10-26	初版				
7	STEEL BALL	STEEL	1	NATURAL	OVER	ISSUE	DATE					
6	SPRING	STEEL WIRE	1	NATURAL	TITLE : VERTICAL SLIDE SWITCH					UNIT : mm	DRWG NO.:	
5	CONTACT CLIP	PBS STRIP	2	Ag PLATED	MODEL:					SCALE: 3:1		
4	TERMINAL	BRASS STRIP	8	Ag PLATED	广东科斯达开关厂					DWN.	2012-10-26	
3	BASE	PHENOLIC RESIN	1	NATURAL						CHK'D		2012-10-26
2	FRAME	STEEL STRIP	1	Ni PLATED						APPD.		
1	KNOB	POM	1	BLACK								