

CAD FILE:

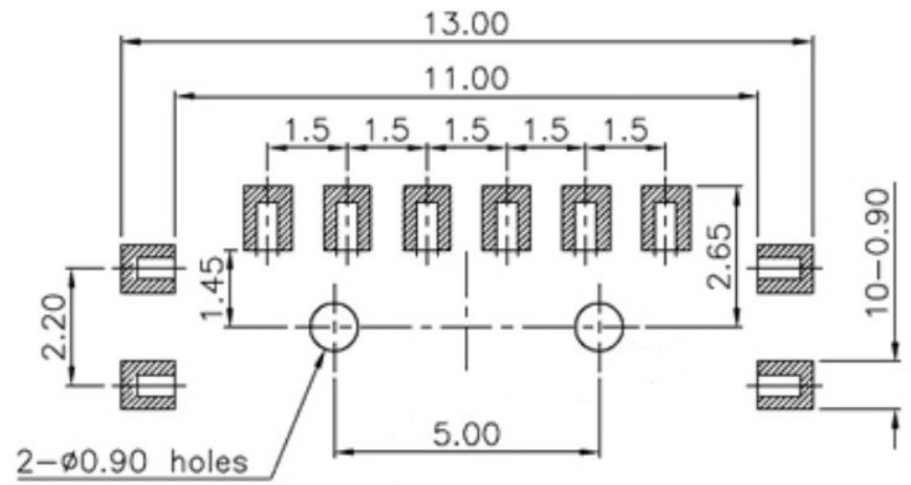

PCB Layout (Pattern side)

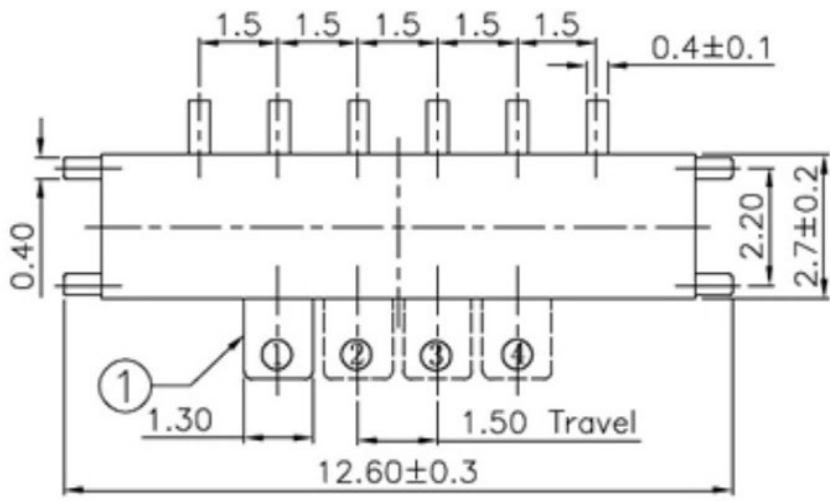
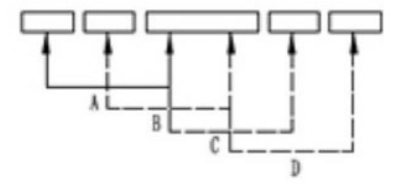
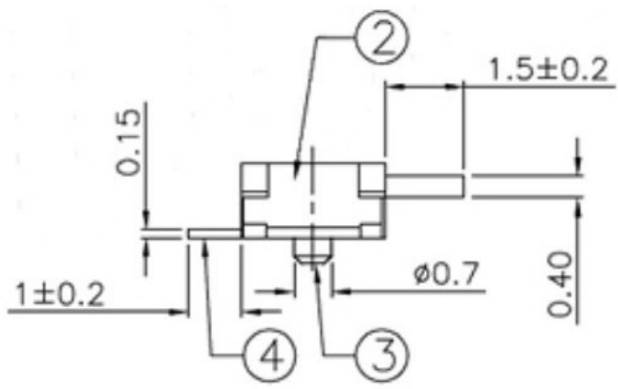
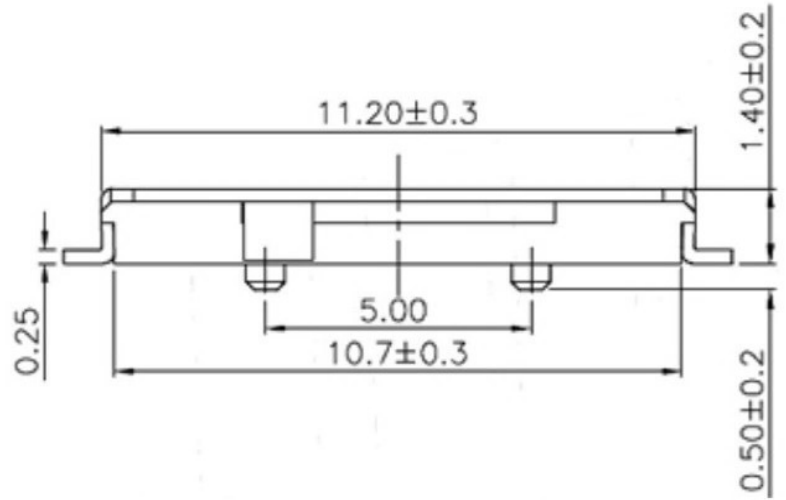

Circuit Diagram

NO.	PARTS	MATERIALS	Q'TY	FINISH
8				
7	STEEL BALL	STEEL	1	NATURAL
6	SPRING	STEEL WIRE	1	NATURAL
5	CONTACT CLIP	PBS STRIP	2	Ag PLATED
4	TERMINAL	BRASS STRIP	8	Ag PLATED
3	BASE	PHENOLIC RESIN	1	NATURAL
2	FRAME	STEEL STRIP	1	Ni PLATED
1	KNOB	POM	1	BLACK

TOLERANCE UNLESS SPECIFIED					
WITHIN	A	2012-10-26	初版		
OVER	ISSUE	DATE	DESCRIPTIONS OF REVISION		APPD.
TITLE : SLIDE SWITCH			UNIT : mm	DRWG NO.:	
MODEL:			SCALE: 3:1	DWN.	2012-10-26
广东科斯达开关厂				CHK'D	
				APPD.	2012-10-26