

Circuit Diagram

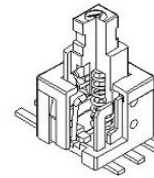

**FEATURES**

- Light operating force.
- Long term low contact resistance.
- Momentary or latching operation.
- Short stroke 1.5mm to latch.
- Compact spacing on PCB of 5.8mm.

**SPECIFICATIONS**

**1.ELECTRICAL**

● Contact rating	0.1A, 30VDC
● Contact resistance	50mWMax.
● Insulation resistance	100MΩMin. at 250VDC
● Dielectric strength	250VAC Min. for 60 sec.

**2.MECHANICAL AND ENVIRONMENTAL**

● Temperature rating	Operating: -15°C to +55°C Storage: -25°C to +65°C
● Operation force	160±80gf
● Stroke	Lock Stroke: 1.5±0.2mm Full Stroke: 2.0±0.2mm
● Operating life	full load: 1x10 <sup>4</sup> cycles no load: 1x10 <sup>5</sup> cycles
● Contact form	DPDT

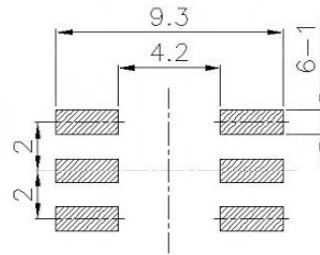
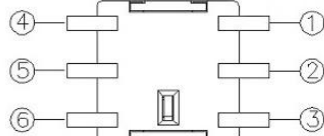
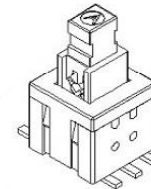
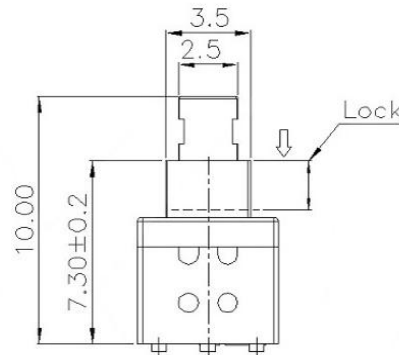
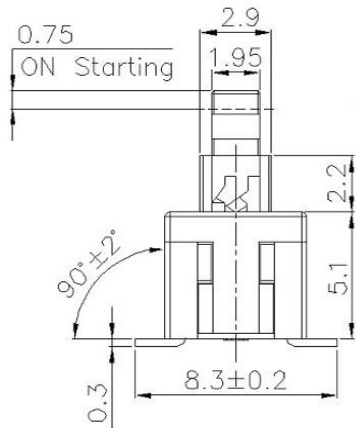

PCB Layout(Pattern Side)

OPERATION	W:NO LOCK Z:LOCK
-----------	------------------

ITEM	PAPT NAMF	TER,NO	QTY	MATERIAL	FINISHING	REMARK
⑦	Contact	—	2	Phosphor bronze	Plating silvering	—
⑥	Terminal	—	6	Brass	Plating silvering	—
⑤	Spring	—	1	Sus	Natural	—
④	Base	—	1	Ppa	—	—
③	Crochet Needle	—	1	Sus	Natural	—
②	Cover	—	1	Ppa	—	—
①	Keystake	—	1	Ppa	—	—

MARK	DESCRIPTION	DATE	REVISED	APPROVED	ANGLAR	±5°
△X					X.X	±0.2mm
△X					X.XX	±0.1mm
△X					X.XXX	±0.05mm
UNSPECIFIED TOLERANCES						

DSND		DATE		SCALE: N/A	MODEL TYPE: KEY SWITCH	
DWN		DATE		VIEW:	PART NO.:	
CHKD		DATE		UNIT: mm	DWG NO.:	
APPD		DATE		SIZE: A4		
				WEIGHT	SHEET	REVISION
				1.0g	1/1	A0

Kosod Technology Co., Ltd.