

开关外形尺寸:

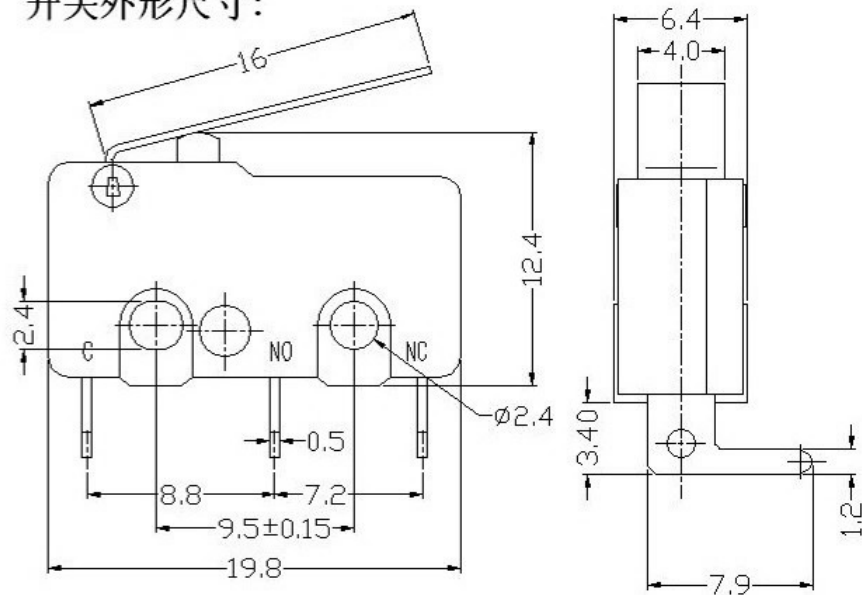

开关技术特性(Switch technical Characteristics):

项目 (ITEM)	技术参数 (technical parameter)	特性值 (Value)
1	电气额定值 (Electrical Rating)	5(2)A 250VAC
2	动作力 (Operating Force)	1.0~5.0N
3	动作行程 (Pretravel)	0.6~1.5mm
4	接触电阻 (Contact Resistance)	≤50mΩ (初始值 Initial value)
5	绝缘电阻 (Insulation Resistance)	≥100MΩ (500VDC)
6	耐压强度 (Dielectric Voltage)	同极不相接端子间 (between non-connected terminals)
		端子与外壳或非载流金属零件之间 (between terminals and the metal frame)
7	电气寿命 (Electrical Life)	≥10000 cycles
8	机械寿命 (Mechanical Life)	≥100000 cycles
9	工作温度 (Operating Temperature)	-25~85℃
10	操作频率 (Operating Frequency)	电气 (electrical) :15 cycles 机械 (Mechanical) :60 cycles
11	抗振动 (Vibration Proof)	振动频率 (Vibration Frequency) : 10~55HZ; 振幅 (Amplitude) : 1.5mm; 三向 (Three directions) :1H
12	可焊性 (Solder Ability): 超过 80% 的浸锡面积被焊料所覆盖 (More than 80% of immersed part shall be covered with solder)	焊接温度 (Soldering Temperature): 235±5℃ 浸渍时间 (Immersing Time): 2~3S
13	耐焊接热 (Solder Heat Resistance)	自动焊接 (Dip Soldering) : 260±5℃ 5±1S 手工焊接 (Manual Soldering) : 300±5℃ 2~3S
14	安全认证 (Safety Approvals)	UL, CSA, CQC
15	测试条件 (Test Conditions)	环境温度 (Ambient Temperature) : 20±5℃ 相对湿度 (Relative Humidity) : 65±5%RH 大气压 (Air Pressure) : 86~106KPa

(The defining characteristics of operation)	(Operating Parameter)	(Abbreviation)	(Units)	(Value)
	自由位置 (Free Position)	FP	mm	12.1 ± 0.2
	动作位置 (Operating Position)	OP	mm	11.5 ± 0.5
	复位位置 (Releasing Position)	RP	mm	11.7 ± 0.5
	总行程位置 (Total travel Position)	TTP	mm	10.7
	动作力 (Operating Force)	OF	N	1.0~3.5
	回复力 (Releasing Force)	RF	N	—
	总行程力 (Total travel Force)	TTF	N	—
	预行程 (Pre Travel)	PT	mm	0.3~1.0
	过行程 (Over Travel)	OT	mm	0.2 (Min)
	差动行程 (Movement Differential)	MD	mm	0.4 (Max)

NO.	PARTS	MATERIALS	Q'TY	TOLERANCE UNLESS SPECIFIED			
8				WITHIN 1.5mm : ±0.1mm	A	2012-8-13	初版
7				OVER 1.5mm : ±0.2mm	ISSUE	DATE	DESCRIPTIONS OF REVISION
6				APPD.			
5	SPRING	SUS	1	NATURAL			
4	CAM STICK	SUS	1	NATURAL			
3	CASE	PA66/BRASS STRIP	1	GREY/Ag PLATED			
2	COVER	PA66	1	BLACK			
1	KNOB	PA66/PBS C5210R-EH	1	WHITE/Ag CLAD			
				TITLE : Miicro Switch		UNIT : mm	DRWG NO.:
				MODEL:		SCALE: 5:1	DWN. 2012-8-13
						CHK'D	2012-8-13
						APPD.	