

ZONE	SYMBOL	REVISION	APPROVAL	DATE
		DIM.ADDED	J.X.KUANG	9-9-2016

RoHS
Compliant

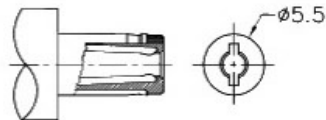
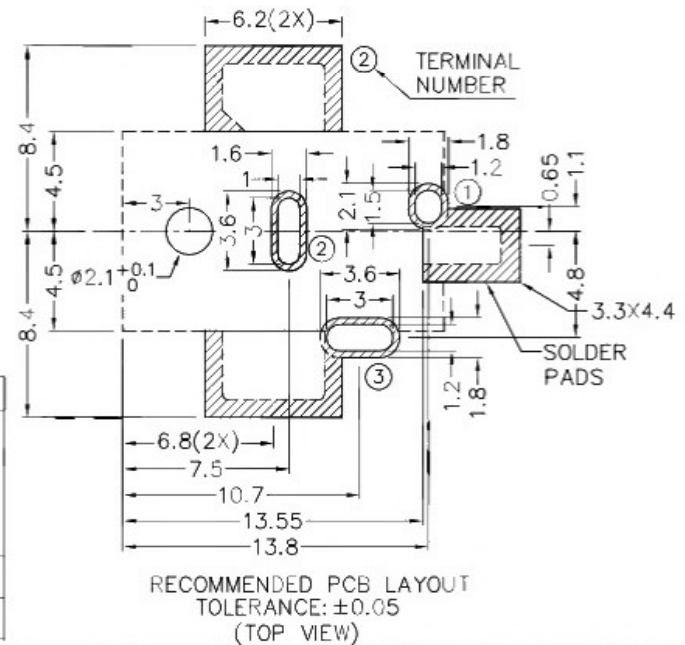
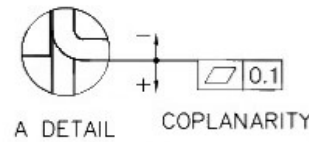
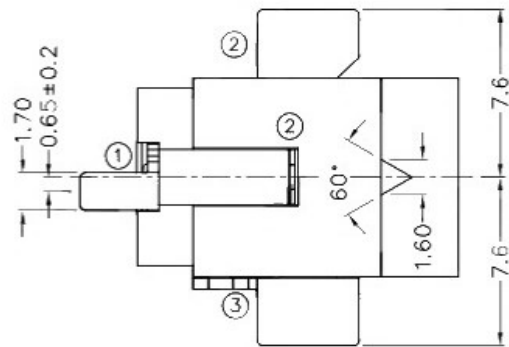
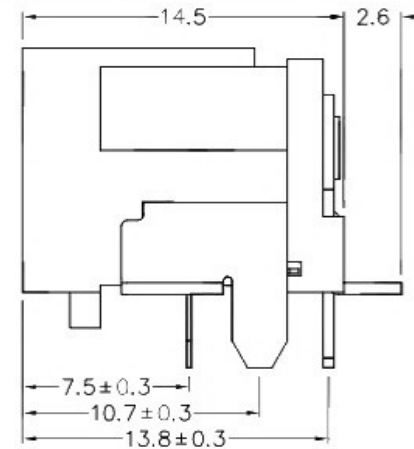
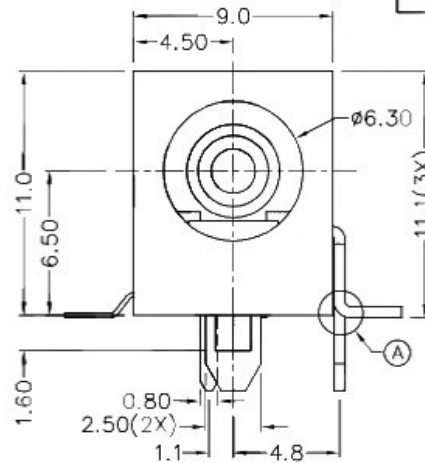
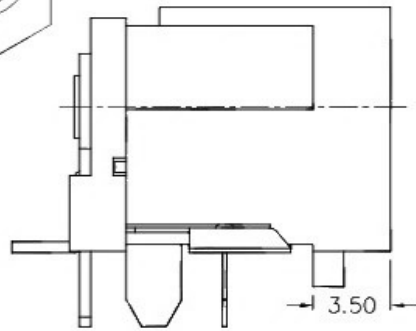
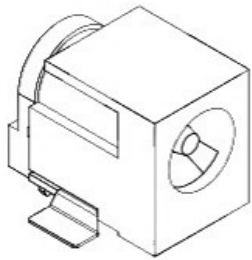

DC MATE PLUG

* MATERIAL

CENTRE PIN : COPPER
 TERMINAL 1 : BRASS
 TERMINAL 2 : COPPER ALLOY
 TERMINAL 3 : BRASS
 HOUSING : HIGH TEMP. PLASTIC
 COVER : HIGH TEMP. PLASTIC

MODEL NO.	
SCHEMATIC	
CENTER PIN	ø2mm ø2.5mm

广东科斯达开关厂

DESIGN	T.Y.LI	DATE	5-7-2005	SCALE	3:1
DRAWING	J.CH.OU	DATE	9-9-2016	MATERIAL	*
CHECK	H.L.TAN	DATE	9-9-2016	DWG. NO.	TZ\DC061DH-3-A/1.1
APPROVAL		DATE		SHEET	

PART NAME	HIGH CURRENT SMD DC POWER SOCKET	TOLERANCE UNLESS	0.0±0.2	UNIT:	
PART NO.		OTHERWISE SPECIFIED:	0.00±0.1 0.000±0.05	mm	