

F

E

D

C

B

A

RoHS
Compliant

ZONE	SYMBOL	REVISION	APPROVAL	DATE
		ADJUST THE RECOMMENDED DC	J.X.KUANG	8-10-2019
		MATING PLUG		

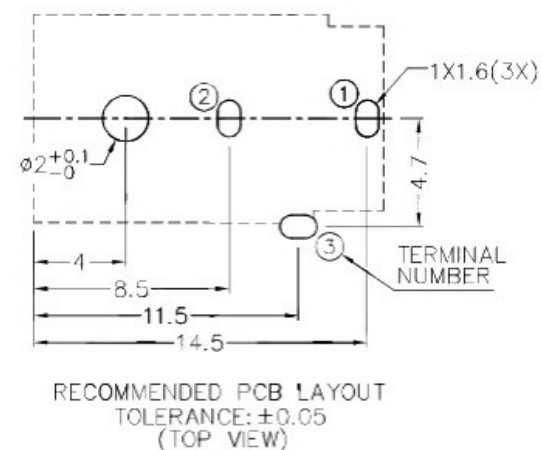
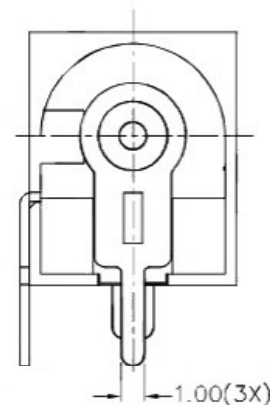
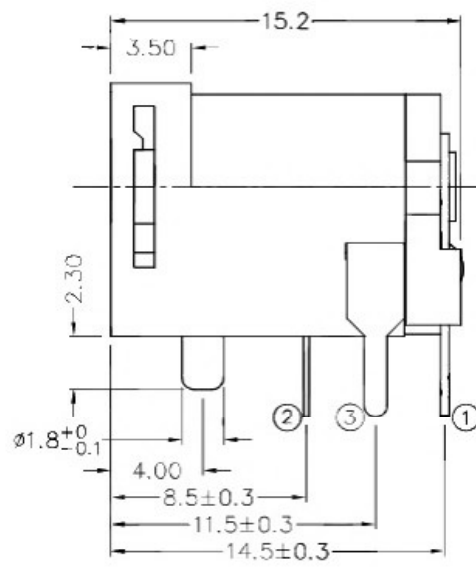
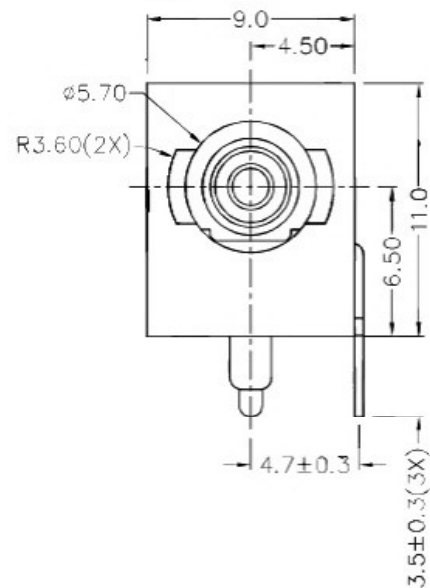
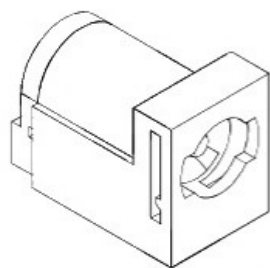

MODEL NO.	
SCHEMATIC	
CENTER PIN	∅2.000mm
	∅2.5 ⁺⁰ _{-0.1} mm

* MATERIAL

CENTRE PIN : COPPER
 TERMINAL 1 : BRASS
 TERMINAL 2 : COPPER ALLOY
 TERMINAL 3 : BRASS
 HOUSING : THERMOPLASTIC
 COVER : THERMOPLASTIC

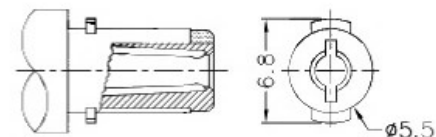

RECOMMENDED
DC SPECIAL MATING PLUG

广东科斯达开关厂

PART NAME	DC POWER SOCKET	TOLFRANCE UNLESS	0.0±0.2	UNIT:
PART NO.		OTHERWISE SPECIFIED:	0.00±0.1 0.000±0.05	

DESIGN	L.L.ZHANG	DATE	23-4-2005	SCALE	3:1
DRAWING	H.Q.ZHOU	DATE	8-10-2019	MATERIAL	*
CHFC	T.Y.LI	DATE	8-10-2019	DWG. NO.	TZ\DC062-3-B/1.2
APPROVAL		DATE		SHEET	

F

E

D

C

B

A