

1. FUNCTION: ON-OFF-ON
ON-OFF-ON
2. RATING: UL: 16A 250VAC 1/4HP 20A 125VAC 1/4HP 250VAC 3/4HP
ENEC VDE/CQC: 16(4)A 250VAC T105
3. OPERATION FORCE: 650±350gf
4. CONTACT RESISTANCE: ≤ 50 mΩ
5. INSULATION RESISTANCE: ≤ 100 MΩ
6. DIELECTRIC WITHSTAND: TERMINAL TO BUTTON 3000VAC/5mA/1MIN/TUE
TERMINAL TO TERMINAL 1500VAC/5mA/1MIN/TUE

7. CIRCUIT DIAGRAM:

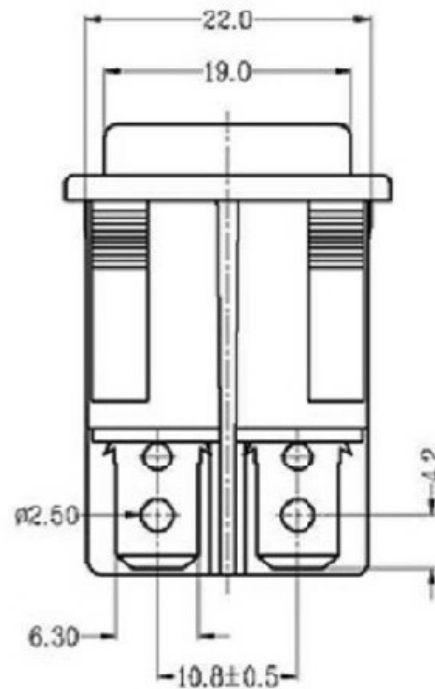
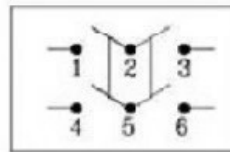

8. SUGGESTED PANEL HOLE SIZE:

PANEL THICKNESS	DIM. X
0.75~1.25	30.1/30.0
1.25~2.0	30.3/30.2
2.0~3.0	30.6/30.5

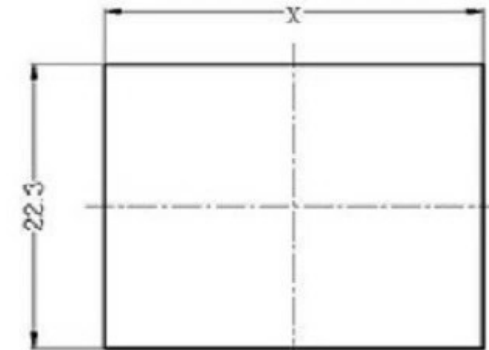

PANEL CUT-OUT

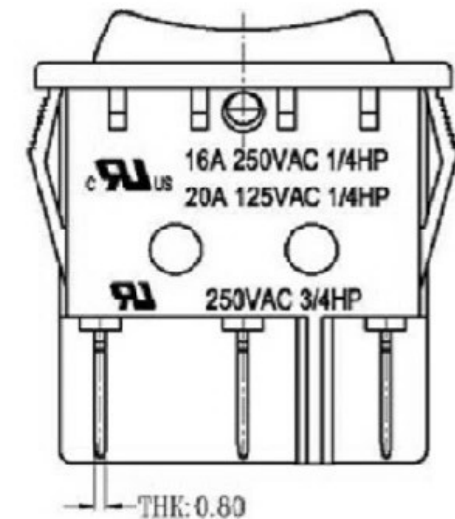

A4				普通公差:	 广东科斯达电子科技有限公司 Guang dong Keside Electronic Technology Co., Ltd.								
A3				COMMON TOLERANCE :									
A2				UP TO 5	±0.20	单位	mm	投影		品名	跳板开关	比例	Free
A1				ABOVE 5 TO 30	±0.30	绘图	周金勇	核 对	梁金勇	型号			
REV.	DATE	REVISION DESCRIPTION	ISSUE	ANGULAR	±5°	日期	2015.8.17	核 准	周培雷	图号			
										DWG NO.	KSD-AC SWITCH		