

- 1、FUNCTION: ON-ON
- 2、RATING: UL: 250VAC 1/2HP 8A 250VAC 10A 125VAC
CQC: 6A/12A 250VAC
ENEC VDE: 12A 125VAC 6(4)A 250VAC μ T105
- 3、OPERATION FORCE: 850 \pm 350g.f
- 4、CONTACT RESISTANCE: \leq 50 m Ω
- 5、INSULATION RESISTANCE: \geq 100 M Ω
- 6、DIELECTRIC WITHSTAND:

TERMINAL TO BUTTON 3000VAC/5mA/1MINTUE
TERMINAL TO TERMINAL 1500VAC/5mA/1MINTUE

7、CIRCUIT DIAGRAM:

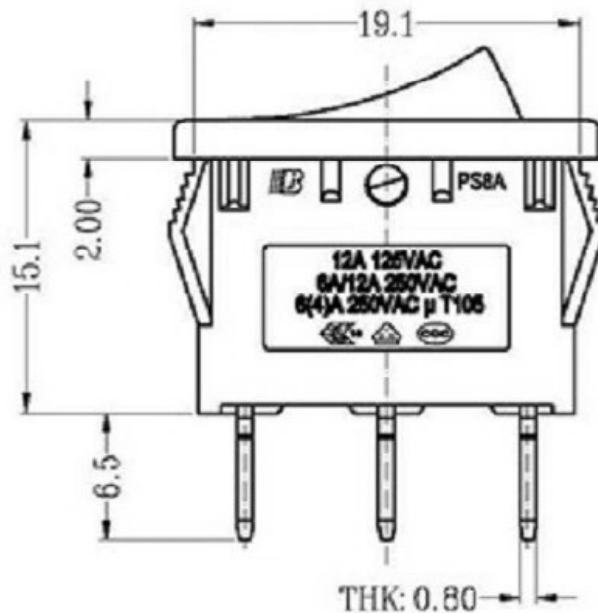
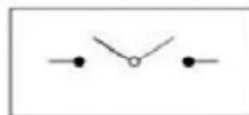

8、SUGGESTED PANEL HOLE SIZE:

PANEL THICKNESS	DIM.X
0.75-1.25	19.2/19.1
1.25-2.0	19.4/19.3
2.0-3.0	19.6/19.7

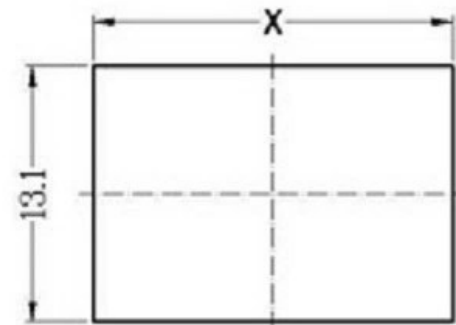

PANEL CUT-OUT

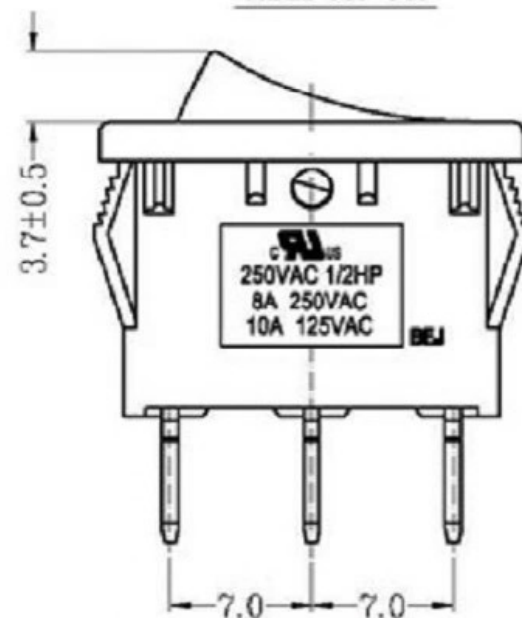

A4				普通公差:	 广东科斯达电子科技有限公司 Guang dong Keside Electronic Technology Co., Ltd.								
A3				COMMON TOLERANCE :									
A2				UP TO 5	\pm 0.20	单位	mm	投影		品名	跷板开关	比例	Free
A1				ABOVE 5 TO 30	\pm 0.30	绘图	周金勇	核 对	梁金勇	型号			
REV.	DATE	REVISION DESCRIPTION	ISSUE	ANGULAR	\pm 5°	日期	2015.8.17	核 准	周培雷	图号			
											KSD-AC SWITCH		