

8. SUGGESTED PANEL HOLE SIZE:

PANEL THICKNESS	DIM. X
0.75-1.25	19.2/19.1
1.25-2.0	19.4/19.3
2.0-3.0	19.8/19.7

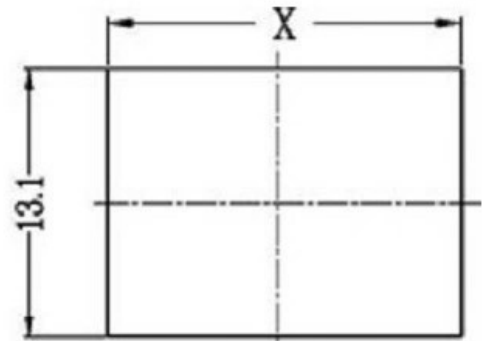

PANEL CUT-OUT

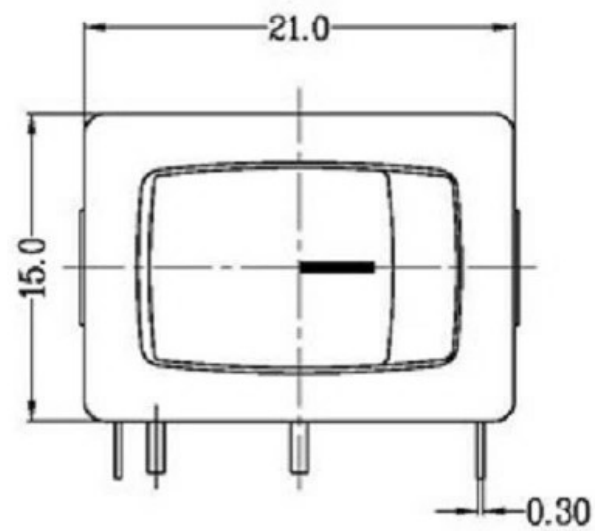

1. FUNCTION: OFF-ON
2. RATING: UL: 250VAC 1/2HP 8A 250VAC 10A 125VAC
CQC: 6A/12A 250VAC
ENEC VDE: 12A 125VAC 6(4)A 250VAC μ T105
3. OPERATION FORCE: 650±350g.f
4. CONTACT RESISTANCE: ≤ 50 mΩ
5. INSULATION RESISTANCE: ≥ 100 MΩ
6. DIELECTRIC WITHSTAND: TERMINAL TO BUTTON 3000VAC/5mA/1MINTUE
TERMINAL TO TERMINAL 1500VAC/5mA/1MINTUE

7. CIRCUIT DIAGRAM:

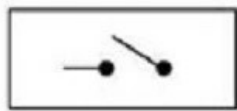

A4				普通公差:	 广东科斯达电子科技有限公司 Guang dong Kesida Electronic Technology Co., Ltd.								
A3				COMMON TOLERANCE :									
A2				UP TO 5	±0.20	单位	mm	投影	⊕ ⊲	品名	跷板开关	比例	Free
A1				ABOVE 5 TO 30	±0.30	UNIT		PROJECTED		PRODUCT NAME		SCALE	
REV.	DATE	REVISION DESCRIPTION	ISSUE	ANGULAR	±5°	绘图	周金勇	核对	梁金勇	型号	KSD-AC SWITCH		
						DRAWN BY		CHECKED BY		MODEL NO.			
						日期	2015.8.17	核准	周培雷	图号			
						DATE		APPROVAL BY		DWG NO.			