

1. FUNCTION: OFF-ON
2. RATING: UL: 250VAC 1/2HP 8A 250VAC 10A 125VAC
CQC: 6A/12A 250VAC
ENEC VDE: 12A 125VAC 6(4)A 250VAC μ T105
3. OPERATION FORCE: 650 \pm 350g.f
4. CONTACT RESISTANCE: \leq 50 m Ω
5. INSULATION RESISTANCE: \geq 100 M Ω
6. DIELECTRIC WITHSTAND:

8. SUGGESTED PANEL HOLE SIZE:

PANEL THICKNESS	DIM. X
0.75-1.25	19.2/19.1
1.25-2.0	19.4/19.3
2.0-3.0	19.8/19.7

TERMINAL TO BUTTON 3000VAC/5mA/1MIN/TUE
TERMINAL TO TERMINAL 1500VAC/5mA/1MIN/TUE

7. CIRCUIT DIAGRAM:

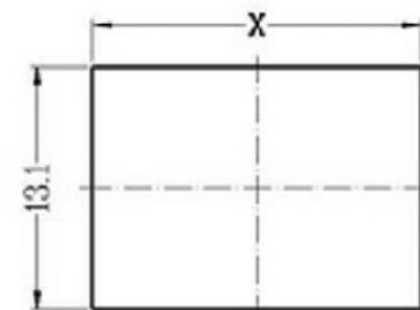
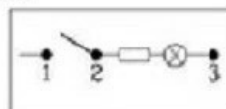

PANEL CUT-OUT

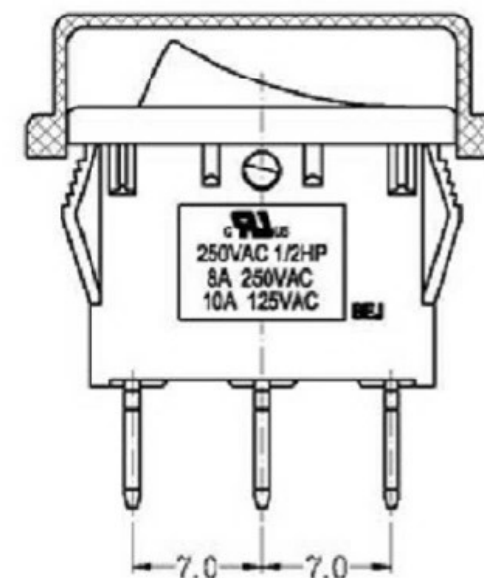
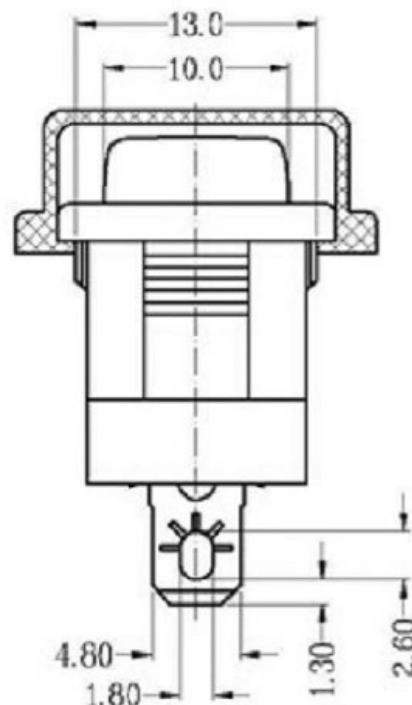
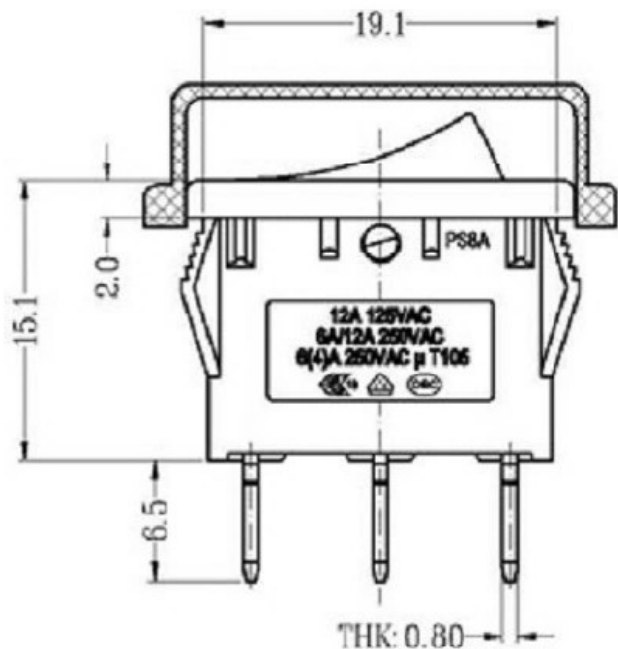

A4				普通公差:	 广东科斯达电子科技有限公司 Guang dong Keside Electronic Technology Co., Ltd.								
A3				COMMON TOLERANCE :									
A2				UP TO 5	± 0.20	单位	mm	投影	$\oplus \triangleright$	品名	跳板开关	比例	Free
A1				ABOVE 5 TO 30	± 0.30	绘图	周金勇	核 对	梁金勇	型号			
				ABOVE 30	± 0.50	日期	2015.8.17	核 准	周培雷	图号			
REV.	DATE	REVISION DESCRIPTION	ISSUE	ANGULAR	$\pm 5^\circ$	日期	2015.8.17	核 准	周培雷	图号	KSD-AC SWITCH		