

DATE	DR.BY	ECN.NO.	DESCRIPTION	MARK	VER.
18/12'06			NEW DWG		AO

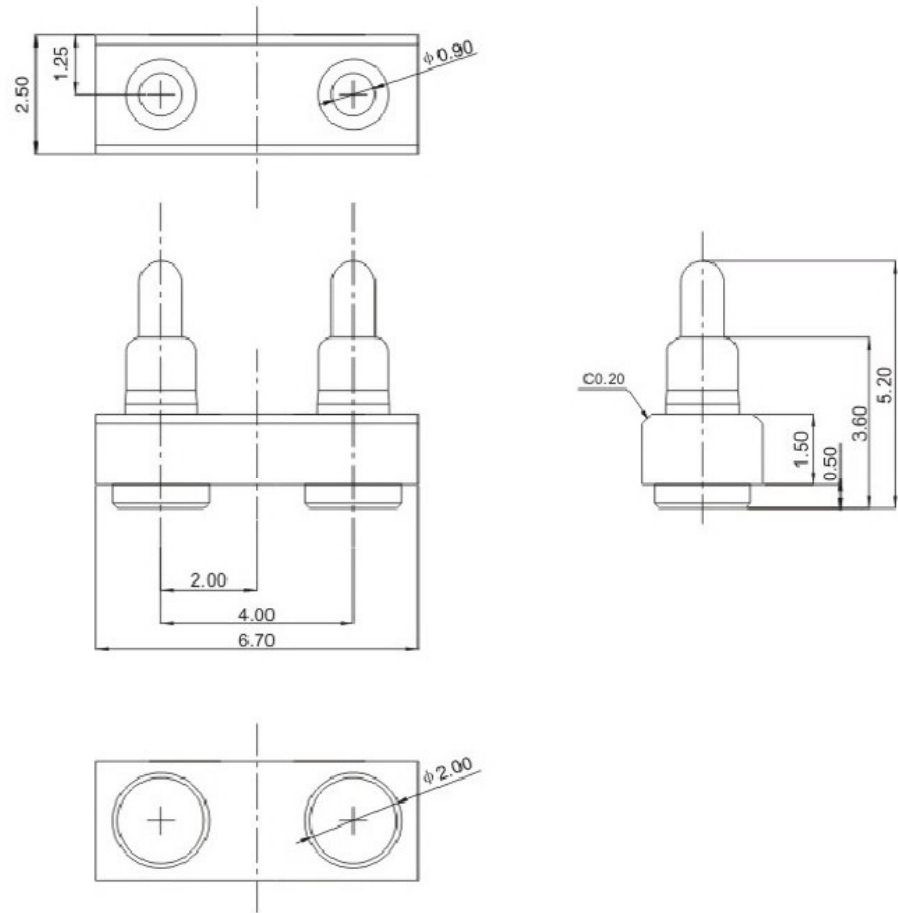

**NOTE:**  
 PRODUCT TO BE MET TYCO SPEC 230-702

**1. MATERIAL**  
 HOUSING: PA46+30%GF,UL94V-0,COLOR:BLACK  
 PLUNGER:BRASS,3u" GOLD PLATING 50u"MIN NICKEL  
 UNDERPLATED  
 BARREL:BRASS,3u" GOLD PLATING OVER 50u"MIN NICKEL  
 UNDERPALTED  
 SPRING:SUS304

**2. SPECIFICATION:**  
 ELECTRICAL  
 CURRENT RATING:12VDC,1A  
 INSULATION RESISTANCE:100m Min  
 CONTACT RESISTANCE:50m Max  
 ENVIRONMENTAL:  
 TEMPERATURE RANGE:-40°C ~85°C

**3.MECHANICAL FUNCTION:**  
 WORKING STROKE:85±20gf AT 1.20mm  
 RECOMMEND STROE  
 MAX.STROKE:1.6mm FULL STROKE  
 DURABILITY:10.000 CYCLES/1.20mm STROKE

- 1. 材料和电镀**  
 接触头为(斜头)黄铜合金(C3604), 镀镍50-70 μ"镀金1 μ"  
 导管为黄铜合金(C3604), 镀镍50-70 μ"镀金1 μ"
- 2. 塑胶材质**  
 PA46+30%玻纤
- 3. 弹力: 120g±10%**
- 4. 持续工作电流: 1A**
- 5. 工作电压: 12V AC/DC**  
 接触电阻: 30mOhm Max
- 6. 使用寿命: 20000次**
- 7. 工作温度计: -40°C - 80°C 90% R. H. Max**
- 8. 中性盐雾测试24小时无锈蚀**

-TOLERANCES- UNLESS OTHERWISE SPECIFIED 公差参考表		 <b>广东科斯达开关厂</b>				
				<b>TITLE:</b> 产品品名: POGO PIN		
		<b>APPD:</b> 核准:		<b>PRODUCT NO:</b> 产品料号:		
		<b>CHECK:</b> 校对:		<b>DATE</b>		
		<b>DRAW:</b> 绘图:		<b>SCALE</b>		
		<b>王芬利</b>		<b>UNIT</b>		
		<b>2016.11.21</b>		<b>TYPE</b>		
		<b>1:1</b>		<b>PAGE</b>		
		<b>mm</b>		<b>1/1</b>		
		<b>CD</b>				