

REV.	DESCRIPTION	NAME	DATE
A	NEWS ISSUE		2018/01/18
B	Modify dimensions		2019/03/22

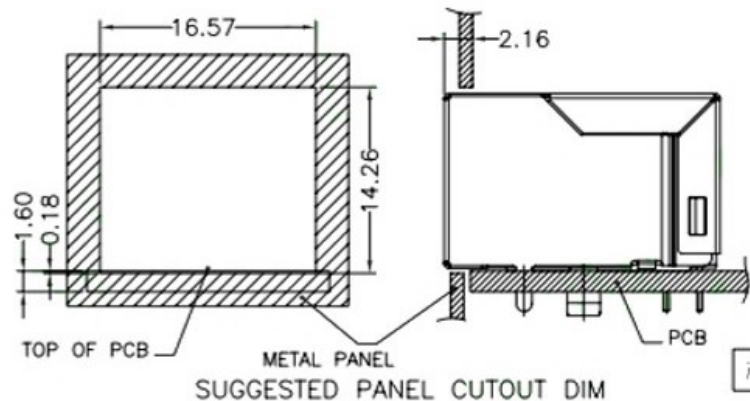
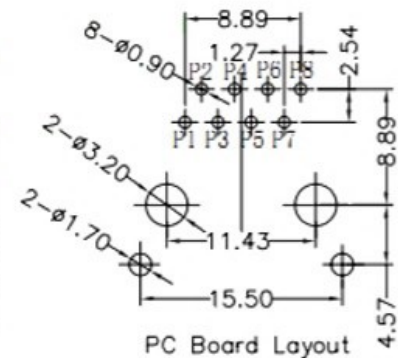
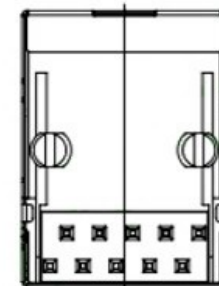
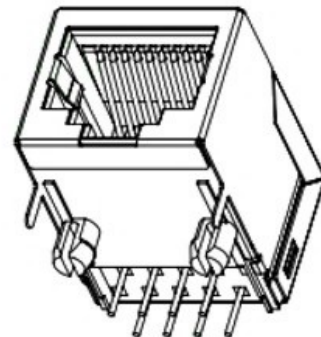
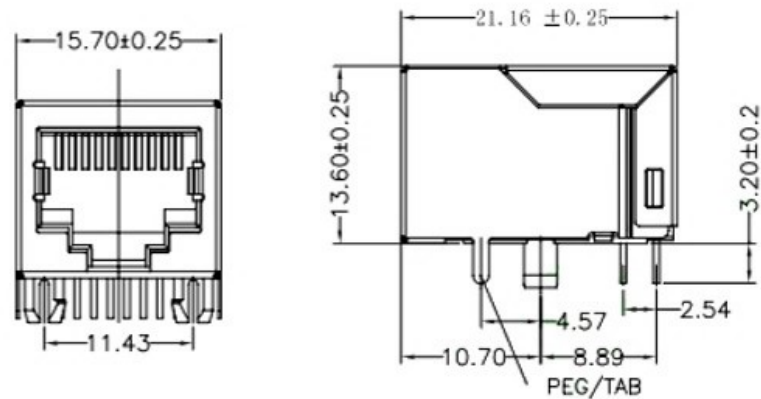

产品背面胶壳底部与铜壳之间距离大于0.80MM

NOTES:

ELECTRICAL:

- VOLTAGE RATING : 125 VAC RMS.
- CURRENT RATING : 1.5 AMP.
- CONTACT RESISTANCE : 30 MILLIOHMSMAX
- INSULATION RESISTANCE : 500 MEGOHMS MIN @ 500 NDC.
- DIELECTRIC STRENGTH : 1000 VAC RMS 50Hz or 60Hz, 1MIN.

MECHANICAL:

- HOUSING & INSERT MATERIAL : PBT UL94V-0.
- CONTACT MATERIAL : DIAMETER: 0.45MM PHOSPHOR BRONZE GOLD PLATING OVER NICKEL.
- SHIELD : 0.20~0.25MM THICKNESS BRASS WITH NI PLATED.
- MATING/UNMATING FORCE : 2.2KG. F MAX.
- RETENTION STRENGTH : 7.7KG. F MIN BETWEEN JACK AND PLUG.
- OPERATING LIFE : 750 CYCLES MIN.

ENVIRONMENTAL:

- STORAGE : -40°C ~+85°C REATIVE HUMIDITY<70%
- OPERATION : -40°C ~+85°C
- IR Reflow Soldering Temperature: 255 To 265 (5-10 Seconds)
Mates With Modular Plug conforming To FCC Part 68, Subpart F.



广东科斯达电子科技有限公司
Guangdong Keside Electronic Technology Co., Ltd.
广东科斯达电器开关厂
Guangdong Keside Electrical Switch Factory

DRAW/ DATE	设计: 李金强	SIZE: A4	UNIT: MM	PART. NO:	料号
CHECKED/ DATE	审核: 赵来锋	SCALE: 1:1	PROJECTION	图号	REV.: 版本
APPROVED/ DATE	核准: 赵佰友	DWG. PATH	图号	SHEET: 页码	