

回路构成

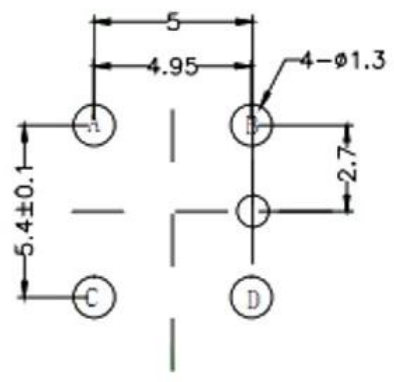
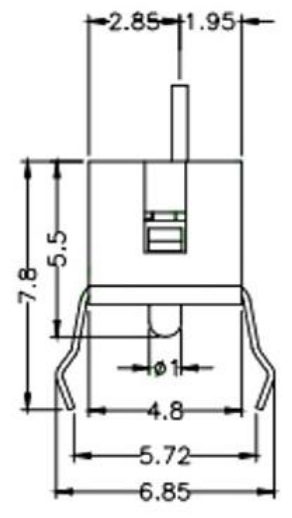
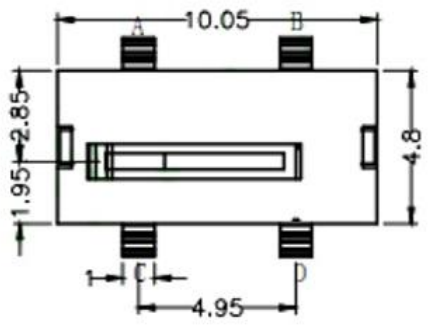

安装尺寸

技术要求

1. 额定负荷: DC 5V 0.1~1mA
2. 绝缘电阻: $\geq 100M\Omega$
3. 耐电压: AC100V 50Hz/1min
4. 电器寿命: 50000次
5. 环境温度: $-10^{\circ} \sim +60^{\circ}$
6. 相对湿度: $40^{\circ}C \leq 95\%$
7. 接触电阻: $\leq 100M\Omega$
8. 接触行程: $0.3+0.2$
9. 动作力: $\leq 0.3N(31gf)$
10. 各零件无明显飞边, 配合要紧密, 不得有明显松动。
11. 未注公差尺寸均按GB1804-m级精度要求。

TITLE	MICRO DETECTOR SWITCH			DRAWN		TOLERANCE OTHERWISE UNLESS SPECIFIED		9				
PART NO.				CHECKED		UP TO 5	± 0.2	8				
DRAW NO.	M18			APPROVED		ABOVE 5 ~ 30	± 0.3	7				
SCALE	4:1	UNIT	mm	DATE	06-12-2001	ABOVE 30 ~ 50	± 0.4	6				
						ABOVE 50	± 0.5	5				
						ANGLE	$\pm 3'$	4	TERMINAL	BRASS	4	Ag PLATED OVER Ni PLATED
								3	HOUSING	NYLON	1	BLACK\Ag PLATED OVER Ni PLATED
								2	COVER	NYLON	1	BLACK
								1	KNOB	NYLON	1	BLACK
								NO.	PARTS	MATERIAL	QTY.	FINISHING

