

SCHEMATIC (NON-SHORTING)

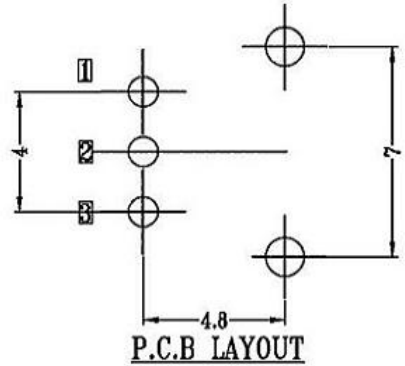
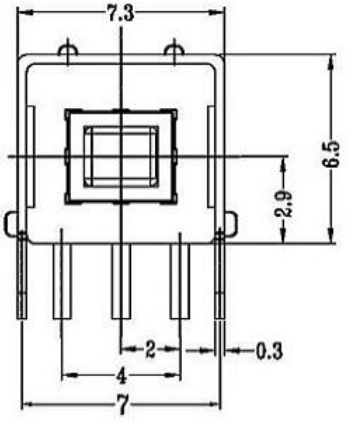

SPECIFICATIONS

- (1)LIFE TEST:10000cycles at a speed of 15-18cycles
- (2)CONTACT RESISTANCE:100mΩmax
- (3)INSULATION RESISTANCE:100MΩmin
- (4)DIELETRIC STRENGTH:250V AC FOR 1MIN
- (5)OPERATING TEMPERATURE:-16°C-+60°C
- (6)RATING: 0.1A 30V DC
- (7)FUNCTION:2P2T
- (8)TIMING:NON-SHORTING
- (9)OPERATING FORCE:180gf±50gf

8					TOLERANCE				
7					UNLESS SPECIFIED				
6					WITHIN 1.5mm : ±0.1mm	A	2016-10-14	初版	
5	SPRING	SUS304	1	NATURAL	OVER 1.5mm : ±0.2mm	ISSUE	DATE	DESCRIPTIONS OF REVISION	APPD.
4	CAM STICK	SUS304	1	NATURAL	TITLE : VERTICAL PUSH SWITCH			UNIT : mm	DRWG NO.:
3	CASE	PA66/BRASS STRIP	1	GREY/Ag PLATED	MODEL:			SCALE: 5:1	
2	COVER	PA66+15%F.G	1	BLACK				DWN.	2016-10-14
1	KNOB	PA66+15%F.G/PBS STRIP	1	BLACK/Ag CLAD				CHK'D	2016-10-14
NO.	PARTS	MATERIALS	Q'TY					APPD.	