

RoHS Compliant

- NOTES:
- ELECTRICAL:
 - VOLTAGE CURRENT RATING: 2AMP, 30V AC;
 - INSULATION RESISTANCE: 1000MΩMIN;
 - CONTACT RESISTANCE: 30mΩMAX;
 - WITHSTANDING VOLTAGE: 500V AC;
 - OPERATING TEMPERATURE: -55°C TO +85°C.
 - Mechanical:
 - Mating Force: 35N MAX
 - Unmating Force: 10N MIN.
 - DIMENSIONS MARKED "▼" TO BE CHECKED BY Q.C & IPQC.
 - PART NO.

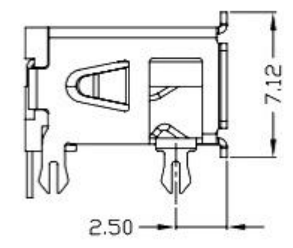
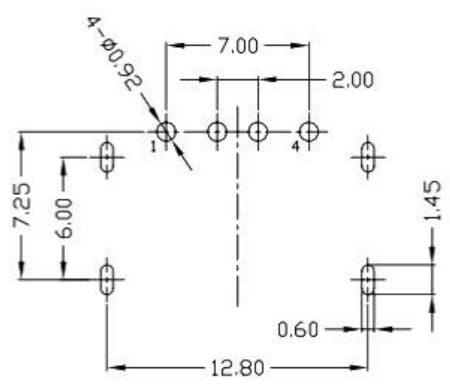
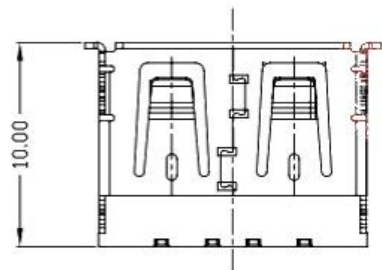
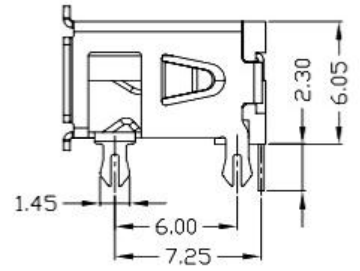
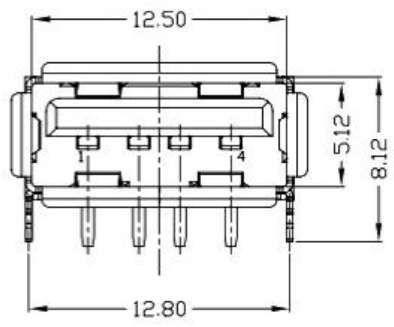
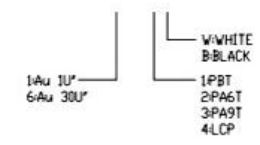
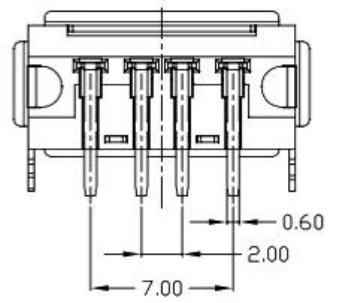
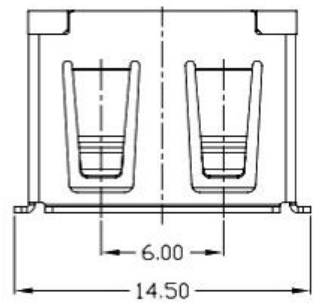

RECOMMENDED PCB LAYOUT

| | | | | | |
|---|------------|---|-----------------|---------------|----------|
| ⑤ | MID PLATE | 1 | STAINLESS STEEL | Au . PLATING. | T=0.15mm |
| ④ | SHELL | 1 | STAINLESS STEEL | Au . PLATING. | T=0.30mm |
| ③ | TERMINAL-B | 1 | TABLE 2: | TABLE 2: | T=0.12mm |
| ② | TERMINAL-A | 1 | TABLE 2: | TABLE 2: | T=0.12mm |
| ① | INSULATOR | 1 | HIGH TEMP | Black | |

| NO. | PART NAME | QTY | MATERIAL | DESCRIPTION | REMARK |
|-----|-----------|-----|----------|-------------|--------|
|-----|-----------|-----|----------|-------------|--------|

UNLESS OTHERWISE, GENERAL TOLERANCE:
 X.xxx ±0.10
 X.xx ±0.20
 X.x ±0.30
 X. ±0.38

ANGULAR:
 X.xx ±1°
 X.x ±3°
 X. ±5°

广东科斯达开关厂

| | | | | | |
|------------------------|---------------|--------|-------|--------|-------------------------------|
| TITLE: | USB connector | | | | P/N: Detail See PART NO. LIST |
| | | | | | MODEL: |
| | | | | | DRAW NO.: |
| THIRD ANGLE PROJECTION | UNIT: | SCALE: | SIZE: | SHEET: | |
| | mm | 1:1 | A4 | 1/1 | |

| | | | | | | | |
|-------------|------|-------------|------------|--------|----------|-----|------------|
| JH2016-080 | X2 | 随工程图上升版本次 | 2016.06.15 | 陈少兵 | DESIGN | 陈少兵 | 2016.06.15 |
| JH2016-071 | X1 | 新增规格 | 2016.06.10 | 陈少兵 | CHECK | 郑小伟 | 2016.06.15 |
| 20151224001 | X | NEW DRAWING | 2016.05.05 | 陈少兵 | APPROVAL | 吕海涛 | 2016.06.15 |
| ECN NO. | REV. | DESCRIPTION | DATE | CHANGE | | | |