

# TL3145 SERIES TACT SWITCH

ANTI-VANDAL SWITCHES  
 DETECTOR SWITCHES  
 DIP SWITCHES  
 KEYLOCK SWITCHES  
 NAVIGATION SWITCHES  
 PUSHBUTTON SWITCHES  
 ROCKER SWITCHES  
 ROTARY SWITCHES  
 SLIDE SWITCHES  
 SNAP ACTION SWITCHES  
**TACTILE SWITCHES**  
 TOGGLE SWITCHES  
 CAP OPTIONS

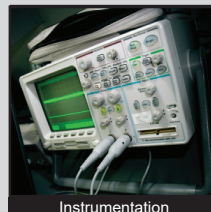

## APPLICATIONS / MARKETS

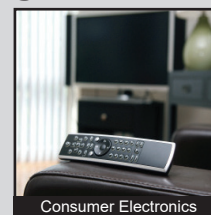
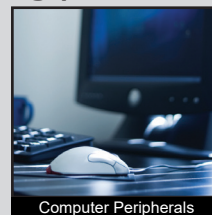
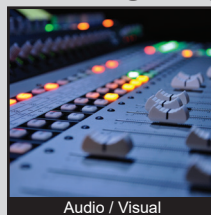

**RoHS**

## SPECIFICATIONS

**Electrical Rating:** 50mA, 12VDC  
**Electrical Life:** up to 3,000,000 Cycles  
**Contact Resistance:** 100mΩ Max.  
**Insulation Resistance:** 100MΩ Min. at 500VDC  
**Dielectric Strength:** 250VAC for 1 Minute  
**Operating Temperature:** -40°C to 85°C  
**Operating Force:** 180gf ± 50gf (3,000,000 cycles)  
                           260gf ± 50gf (500,000 cycles)  
                           350gf ± 80gf (500,000 cycles)  
**Travel:** 0.5mm  
**Dust/Moisture Protection:** IP67  
**Function:** SPST, Off-(On)

## FEATURES & BENEFITS

- Up to 3,000,000 cycle life expectancy
- Tape and Reel packaging
- IP67 ratings
- Multiple force options

## PART NUMBER CONFIGURATOR

Series	Circuit	Actuator	Force	Plating	Termination
TL	3145	A - 3.50 B - 5.20	F180 - 180 gf - White F260 - 260 gf - Red F350 - 350 gf - Orange	Q - Silver	J - J Lead

*Specifications subject to change without notice 7.6.2021*

# TL3145 SERIES TACT SWITCH

## BODY DIMENSIONS

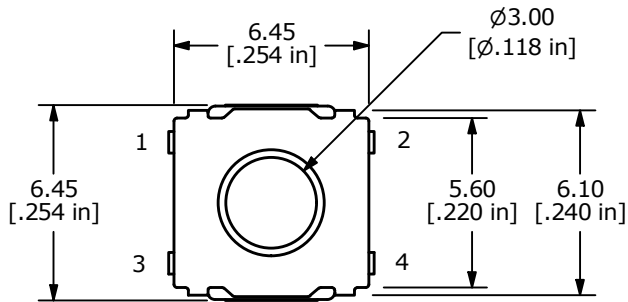
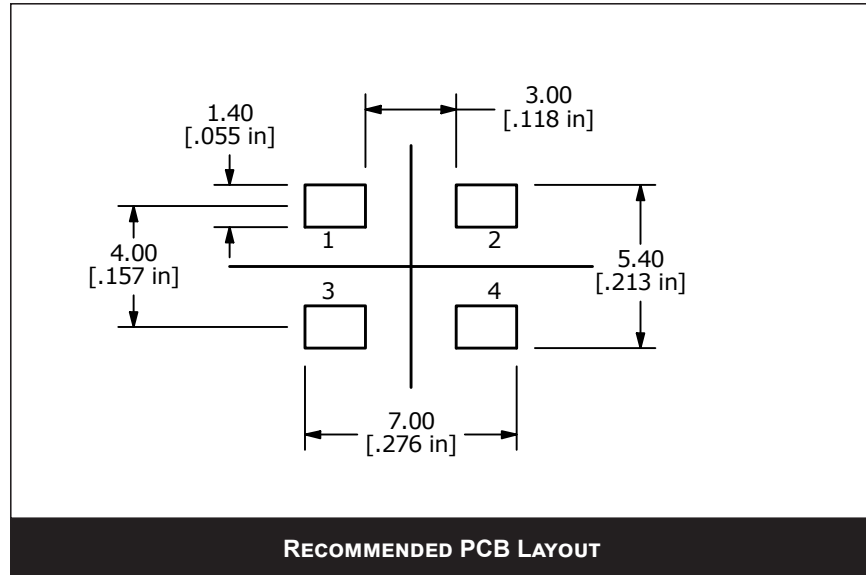
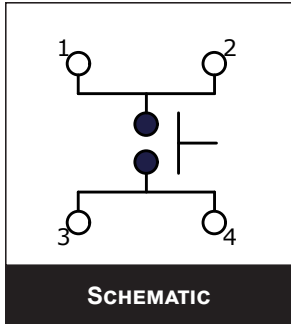

ACTUATOR	"X"
A	3.50
B	5.20

