

TL1015 SERIES TACT SWITCH

ANTI-VANDAL SWITCHES
 DETECTOR SWITCHES
 DIP SWITCHES
 KEYLOCK SWITCHES
 NAVIGATION SWITCHES
 PUSHBUTTON SWITCHES
 ROCKER SWITCHES
 ROTARY SWITCHES
 SLIDE SWITCHES
 SNAP ACTION SWITCHES
TACTILE SWITCHES
 TOGGLE SWITCHES
 CAP OPTIONS

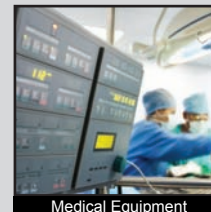

APPLICATIONS / MARKETS

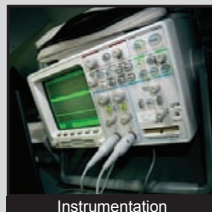
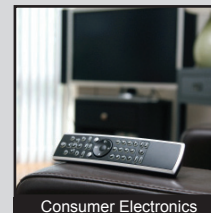
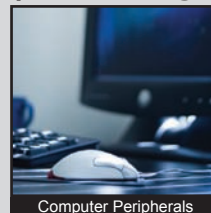
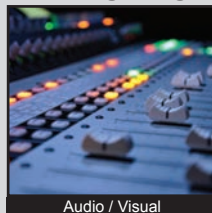

RoHS

SPECIFICATIONS

Electrical Rating: 50mA @ 12VDC
Life Expectancy: 200,000 cycles
Contact Resistance: 100mΩ Max. Initial
Insulation Resistance: 100 MΩ Min. at 500V
Dielectric Strength: 100VAC for 1 min.
Operating Temperature: -20°C to 70°C
Storage Temperature: -40°C to 80°C
Operating Force: 160 gf
Travel: 0.20mm
Contact Arrangement: SPST

FEATURES & BENEFITS

- Tape & Reel packaging
- Surface mount termination - top actuated
- Ultra-miniature in size

PART NUMBER CONFIGURATOR

Series	Boss	Actuation Force	Contact Plating	Termination
<input type="text" value="TL"/> <input type="text" value="1"/> <input type="text" value="0"/> <input type="text" value="1"/> <input type="text" value="5"/>	<input type="text" value="A"/>	<input type="text" value="F"/> <input type="text" value="1"/> <input type="text" value="6"/> <input type="text" value="0"/>	<input type="text" value="Q"/>	<input type="text" value="G"/>
TL1015	A - No boss	F160 - 160 gf	Q - Silver	G - Gullwing

Specifications subject to change without notice

TL1015 SERIES TACT SWITCH

BODY DIMENSIONS

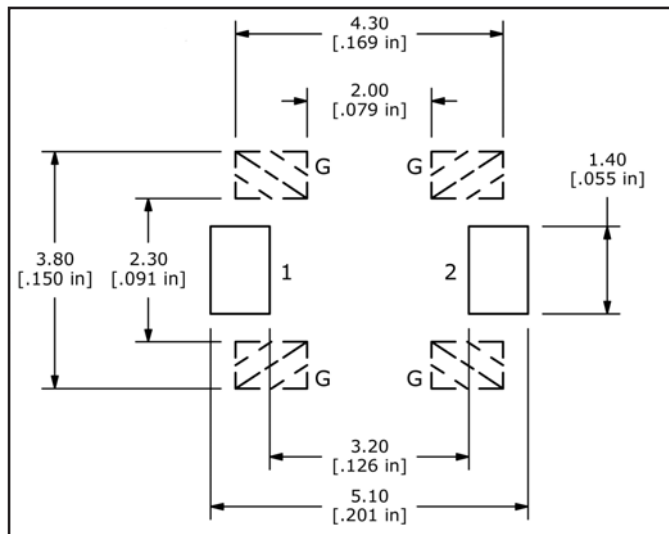
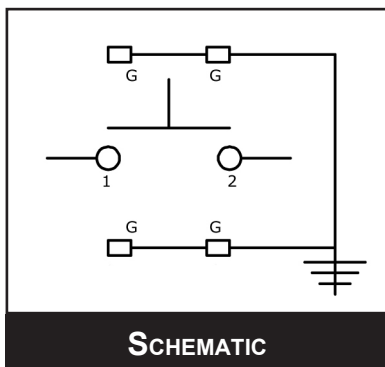
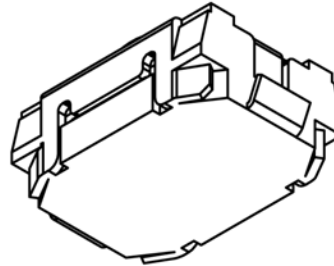
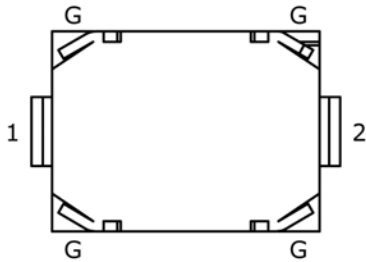
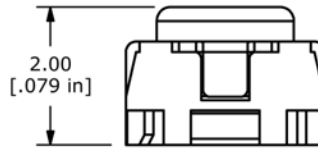
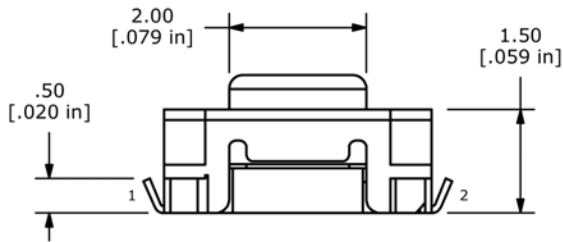
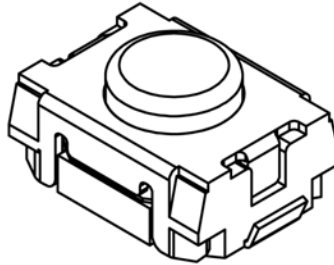
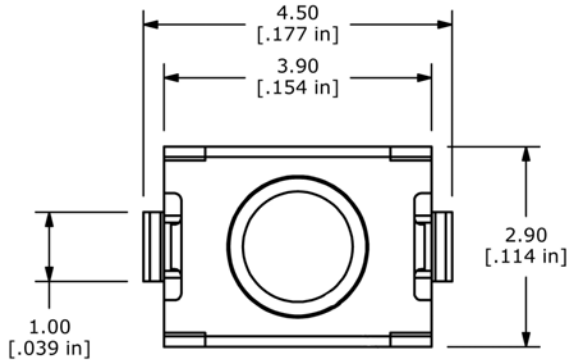

PCB LAYOUT (GROUND TERMINALS OPTIONAL)

- ANTI-VANDAL SWITCHES
- DETECTOR SWITCHES
- DIP SWITCHES
- KEYLOCK SWITCHES
- NAVIGATION SWITCHES
- PUSHBUTTON SWITCHES
- ROCKER SWITCHES
- ROTARY SWITCHES
- SLIDE SWITCHES
- SNAP ACTION SWITCHES
- TACTILE SWITCHES**
- TOGGLE SWITCHES
- CAP OPTIONS