

RBW2 SERIES ROCKER SWITCH

ANTI-VANDAL SWITCHES
DETECTOR SWITCHES
DIP SWITCHES
KEYLOCK SWITCHES
NAVIGATION SWITCHES
PUSHBUTTON SWITCHES
ROCKER SWITCHES
ROTARY SWITCHES
SLIDE SWITCHES
SNAP ACTION SWITCHES
TACTILE SWITCHES
TOGGLE SWITCHES
CAP OPTIONS



APPLICATIONS / MARKETS



RoHS

SPECIFICATIONS

Electrical Rating: 16(16)A 125VAC 5E4 T85 [cURus]
1/3HP 125VAC IP66 [cURus]
Electrical Life: 50,000 Cycles
Mechanical Life: 50,000 Cycles
Contact Resistance: <30mΩ Max.
Insulation Resistance: 500MΩ Min. at 500VDC
Dielectric Strength: 1,000VAC for 1 Minute
Operating Temperature: -20°C to 85°C
Ingress Protection: IP66
Panel Cutout: 22mm x 30mm
Function: DPST, Off-On DPDT, On-On

FEATURES & BENEFITS

- Full illumination options available
- Approved under new UL 61058-1 rating
- UL approved up to 1/3HP
- Internally sealed to an IP66 rating using patented technology (Patent No.: US 7,872,205 B2)

PART NUMBER CONFIGURATOR

| Series | Circuit | Body Color | Actuator Color | Marking | Termination | Lamp Voltage |
|-----------------------------------|--|----------------------------------|--|---|--------------------------------|---|
| <input type="text" value="RBW2"/> | <input type="text" value="A"/> | <input type="text" value="BLK"/> | <input type="text" value="BLK"/> | <input type="text" value="A"/> | <input type="text" value="F"/> | <input type="text" value="0"/> |
| | A - Off-On (DPST) *B - On-On (DPDT) | BLK - Black WHT - White | BLK - Black WHT - White RIL - Red Full Illumin. GIL - Green Full Illumin. YIL - Yellow Full Illumin. BIL - Blue Full Illumin. | A - Dot D - I/II Vertical F - I/O Vertical G - I/O Horizontal I - On/Off Vertical E - No Marking | F - 6.3mm Tab | 0 - No Lamp 1 - 125VAC Neon 2 - 250VAC Neon 3 - 12VDC Incandescent |

* Not available with Illuminaiton

Specifications subject to change without notice 11.16.2021

RBW2 SERIES ROCKER SWITCH

BODY DIMENSIONS A - CIRCUIT

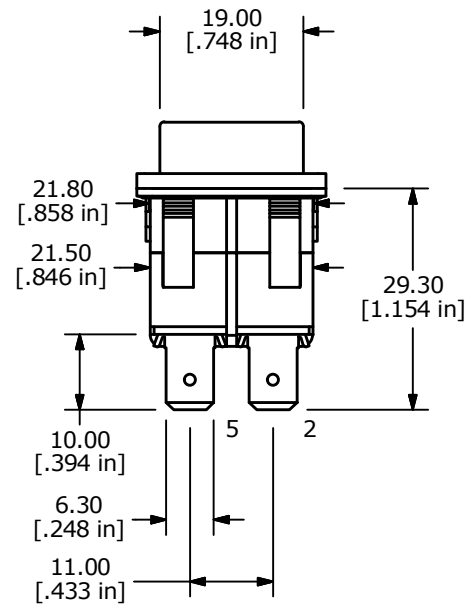
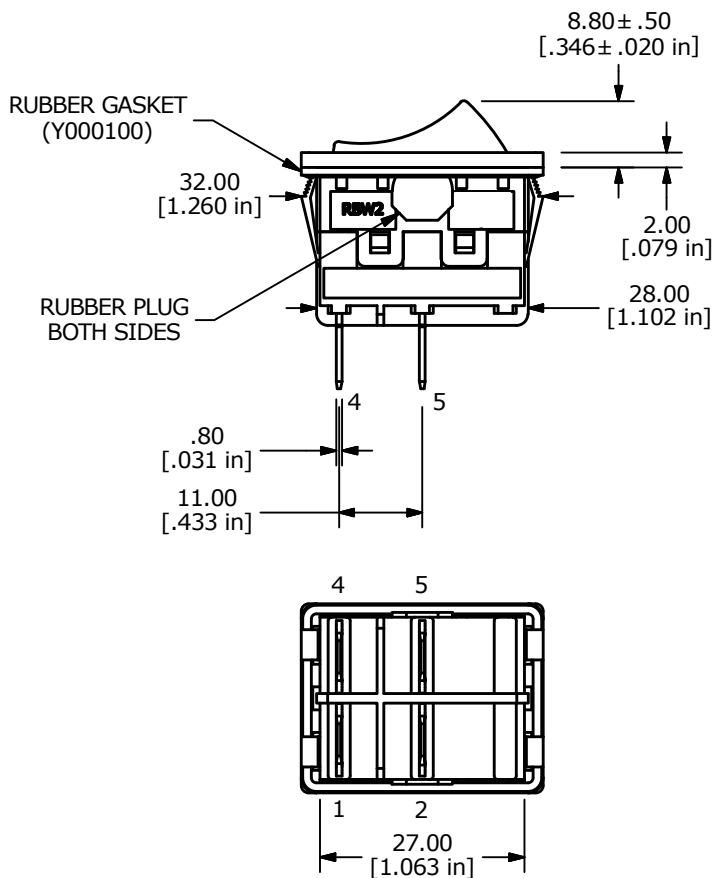
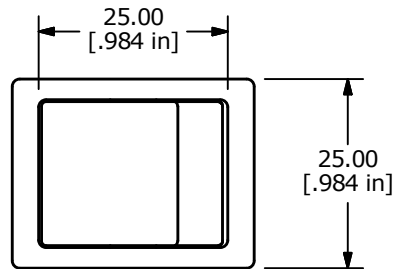
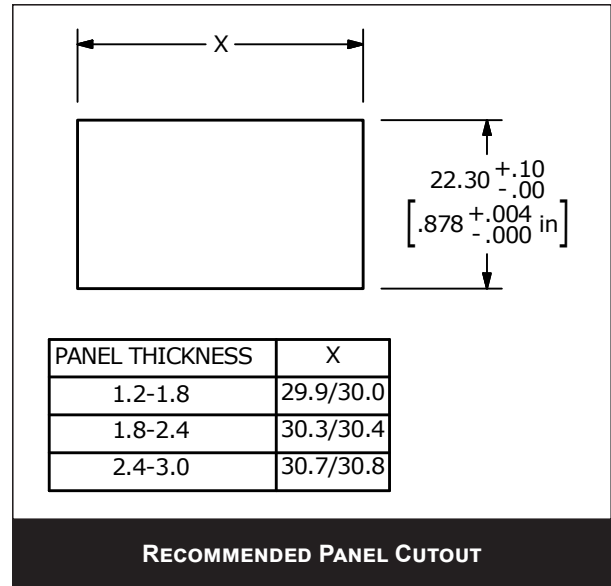
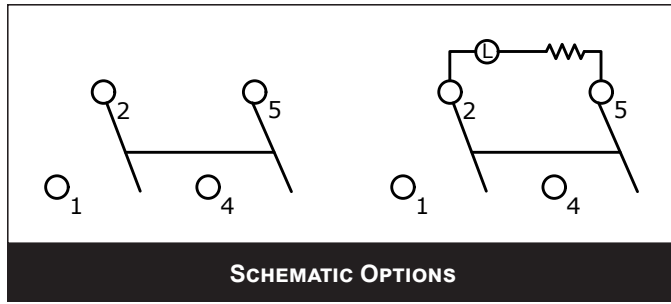

RBW2 SERIES ROCKER SWITCH

BODY DIMENSIONS B - CIRCUIT

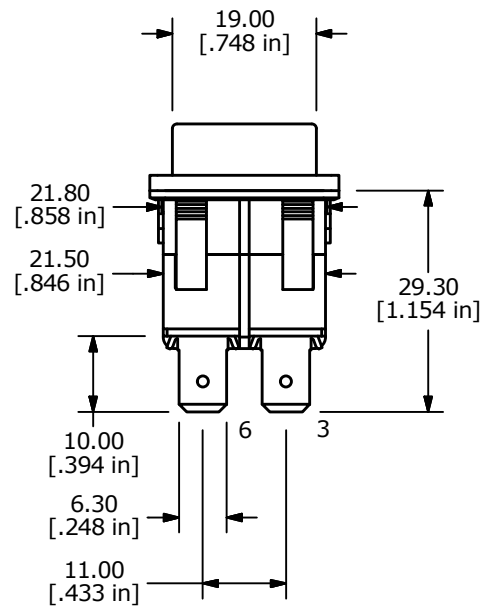
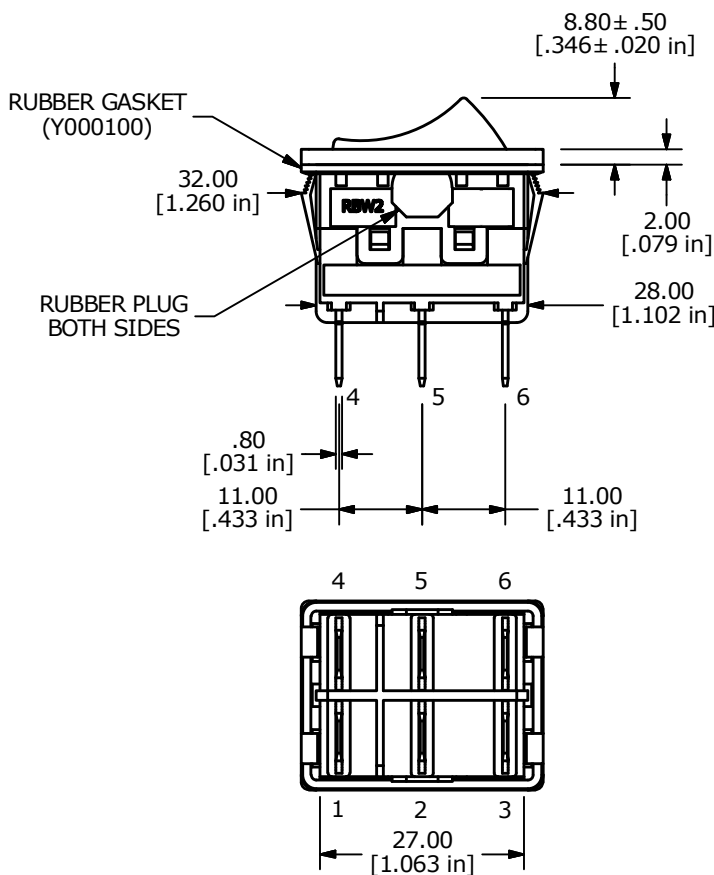
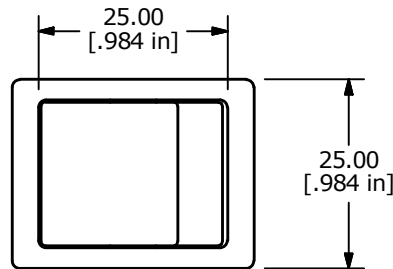
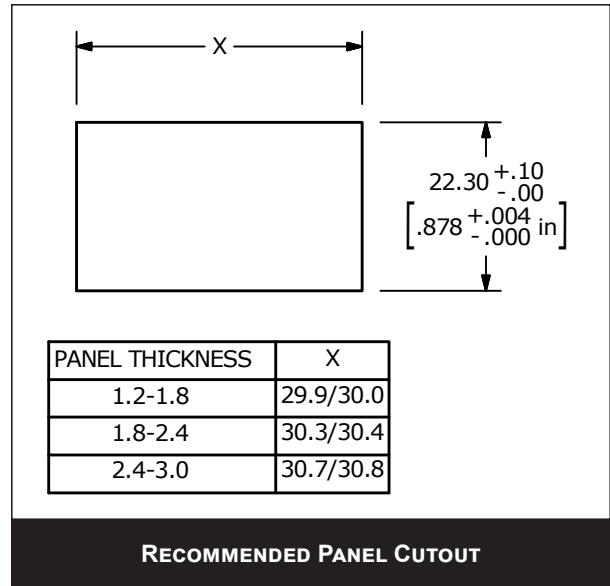
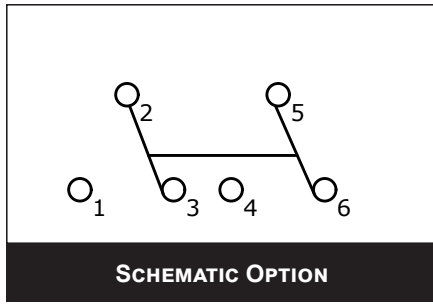

RBW2 SERIES ROCKER SWITCH

MARKING OPTIONS

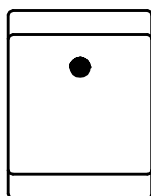

A - DOT

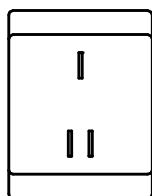

**D - I/II
VERTICAL**

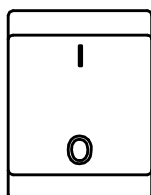

**F - I/O
VERTICAL**

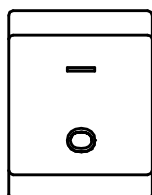

**G - I/O
HORIZONTAL**

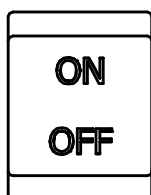

**I - ON/OFF
VERTICAL**

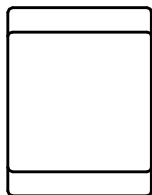

E - No MARKING

ANTI-VANDAL
SWITCHES

DETECTOR
SWITCHES

DIP
SWITCHES

KEYLOCK
SWITCHES

NAVIGATION
SWITCHES

PUSHBUTTON
SWITCHES

**ROCKER
SWITCHES**

ROTARY
SWITCHES

SLIDE
SWITCHES

SNAP ACTION
SWITCHES

TACTILE
SWITCHES

TOGGLE
SWITCHES

CAP
OPTIONS