

SERIES LS SWITCHES

SNAP ACTION SWITCHES

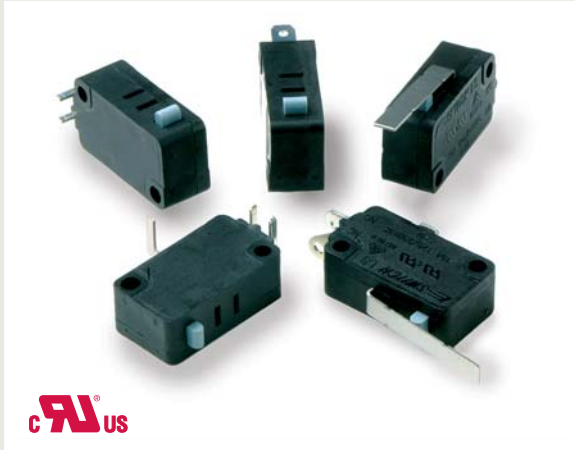

SPECIFICATIONS

Contact Rating:	Gold .4VA max. @ 20 VDC or VAC Max. 15 Amps @ 125/250 VAC-UL, CUL
Life Expectancy:	10,000 VAC-UL, CUL / 50,000 cycles typical
Mechanical Life:	1,000,000 cycles typical
Insulation Resistance:	100 MΩ min.
Dielectric Strength:	1,500 VAC for 60 seconds
Operating Temperature:	-25° C to 85° C (std)
Operating Force:	See Chart

FEATURES & BENEFITS

- ▶ Available in gold & 15amp versions
- ▶ Wide variety of actuator, operating force & termination options

APPLICATIONS/MARKETS

- ▶ Appliance
- ▶ Timing controls
- ▶ Vending machines
- ▶ Gaming
- ▶ Industrial controls
- ▶ Power tools

HOW TO ORDER

SERIES	OPERATING TEMP.	CURRENT RATING	ACTUATOR	OPERATING FORCE	TERMINATION	CIRCUIT
LS	085 = 85C	R1 = Gold .4VA 15 = 15A	See Chart	See Chart	S1 = Solder Lug C1 = 0.187" Quick Connect C2 = 0.250" Quick Connect V1 = Right Angle PCB Pin V2 = Left Angle PCB Pin	A = SPDT B = SPST NC C = SPST NO

Example Ordering Number

LS-085-15-03-F040-C2-A

Specifications subject to change without notice 11.16.21

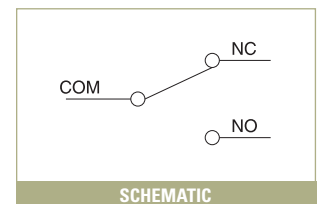
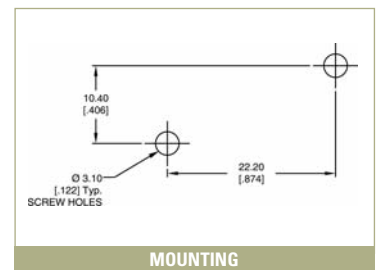
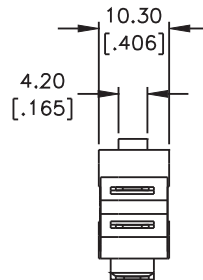
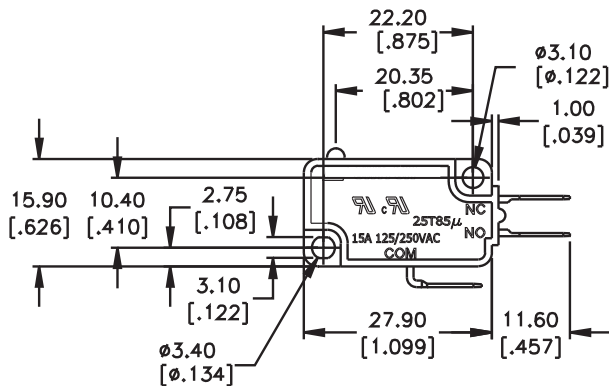

TACT SWITCHES
NAVIGATION SWITCHES
PUSHBUTTON SWITCHES
TOGGLE SWITCHES
ROCKER SWITCHES
SLIDE SWITCHES
SNAP-ACTION SWITCHES
DIP SWITCHES
KEYLOCK SWITCHES
ROTARY SWITCHES
DETECTOR SWITCHES
CAP OPTIONS



SERIES LS SWITCHES

SNAP ACTION SWITCHES

TACT SWITCHES

NAVIGATION SWITCHES

PUSHBUTTON SWITCHES

TOGGLE SWITCHES

ROCKER SWITCHES

SLIDE SWITCHES

SNAP-ACTION SWITCHES

DIP SWITCHES

KEYLOCK SWITCHES

ROTARY SWITCHES

DETECTOR SWITCHES

CAP OPTIONS

ACTUATOR OPTIONS

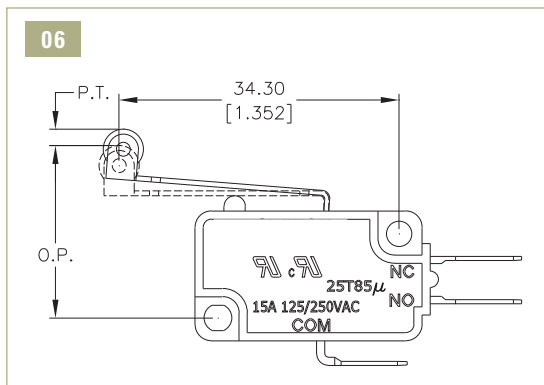
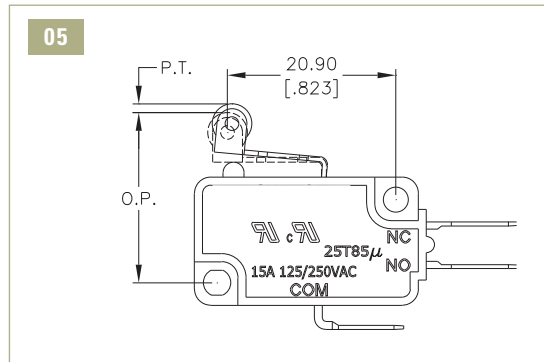
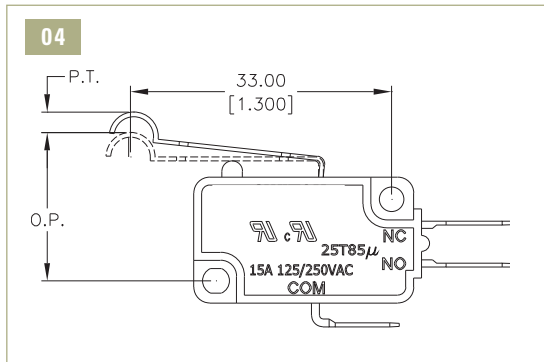
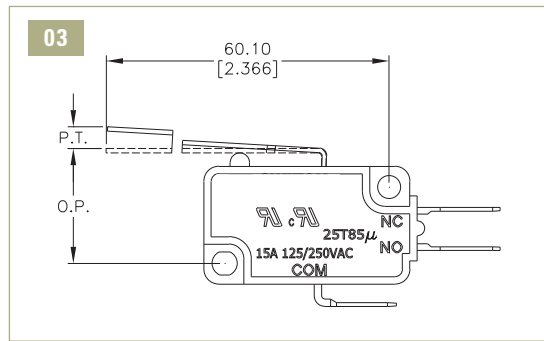
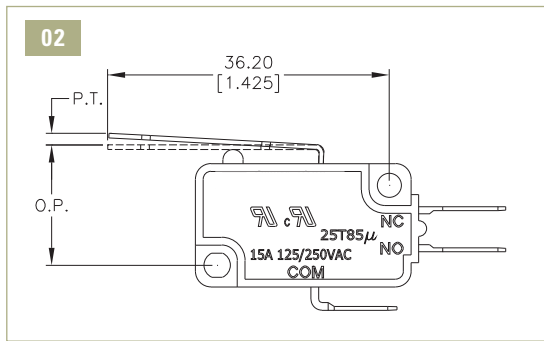
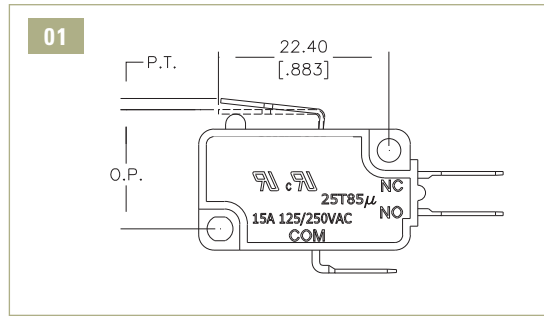
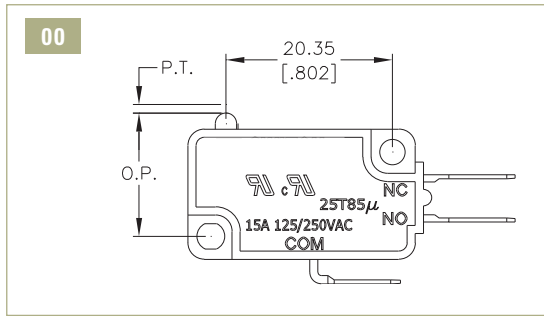

ACTUATOR AND OPERATING FORCE CHART					
Actuator	Actuation/Return Force			Pre-Travel	Operating Position
00	100+/-30	160+/-40	250+/-50	2.0 max	14.7+/-0.5
01	100+/-30	160+/-40	250+/-50	2.0 max	15.3+/-0.5
02	45+/-20	75+/-25	120+/-40	4.1 max	15.5+/-0.8
03	25+/-10	40+/-15	60+/-25	8.5 max	15.3+/-2.0
04	50+/-20	85+/-30	140+/-40	5.2 max	19.0+/-1.5
05	100+/-30	160+/-40	250+/-50	2.7 max	20.7+/-0.8
06	45+/-15	75+/-25	120+/-40	5.5 max	20.7+/-1.5

PT= Pretravel OP= Operating Point OT= Over Travel

TERMINATION OPTIONS

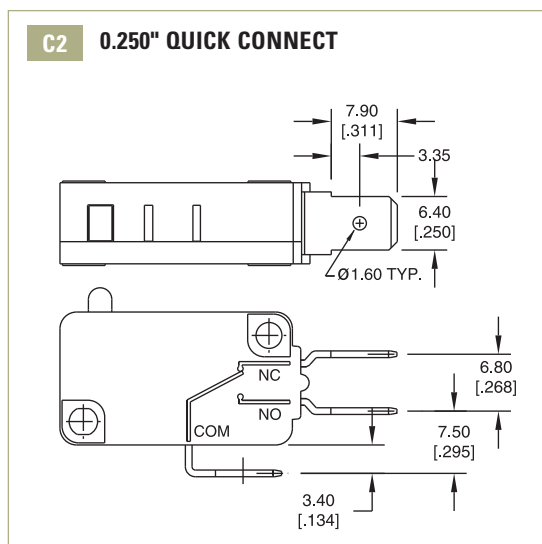
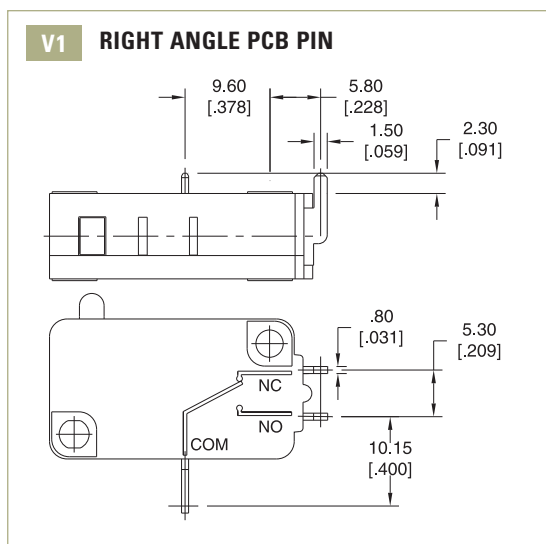
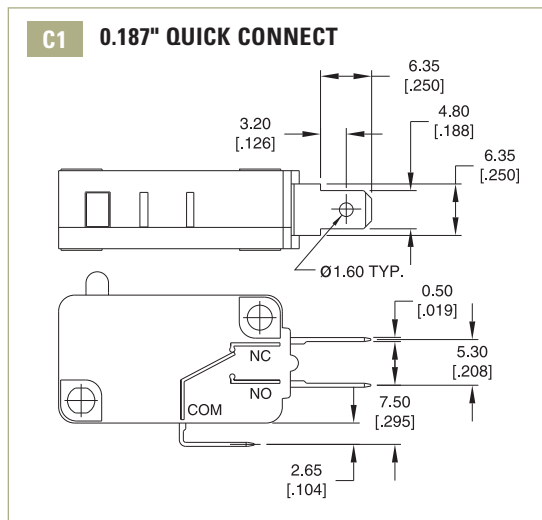
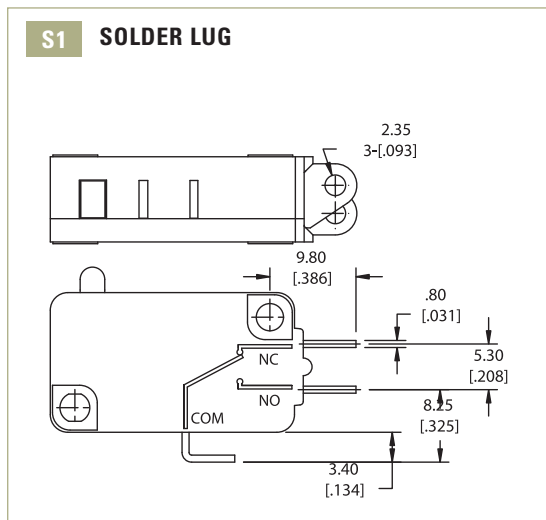

TACT SWITCHES

NAVIGATION SWITCHES

PUSHBUTTON SWITCHES

TOGGLE SWITCHES

ROCKER SWITCHES

SLIDE SWITCHES

SNAP-ACTION SWITCHES

DIP SWITCHES

KEYLOCK SWITCHES

ROTARY SWITCHES

DETECTOR SWITCHES

CAP OPTIONS