

P.C.B LATOUT TOP VIEW

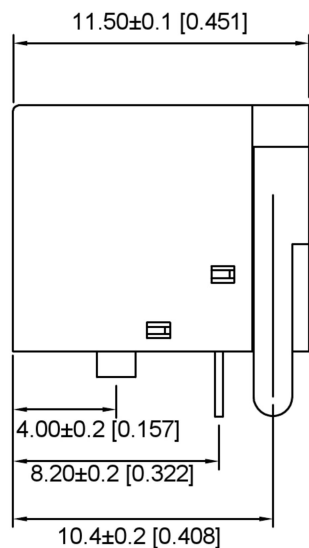
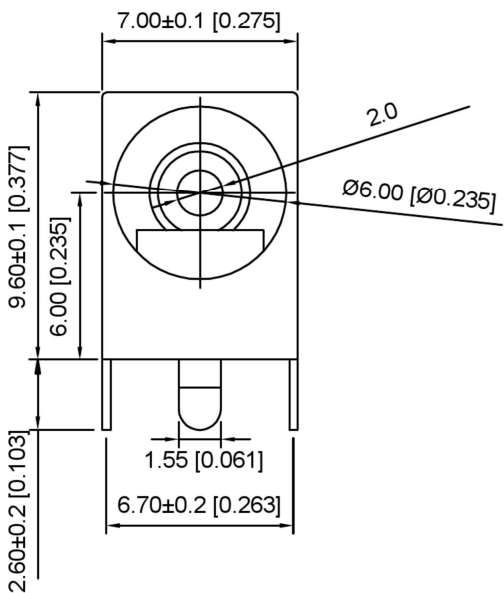

Specifications:

规格:

- 1.Voltage rating:12VAC/DC
额定电压: 12V AC/DC
- 2.Current rating:3A AC/DC
额定电流: 3A AC/DC
- 3.Withstanding voltage:500V AC/minute
耐受电压: ≥500V AC/分钟
- 4.Temperature range: -30 °C-+70 °C
温度范围: -30°C-+70°C
- 5.Insulation resistance:100MΩMIN
绝缘电阻: ≥100MΩ
- 6.Contact resistance:30mΩMax
接触电阻: ≥30mΩ
- 7. Life:5000 cycles
寿命: 5000次
- 8. Insertion and extrsrction force : 3-20N
插拔力: 3-20N

| | |
|------------|----------|
| SCHEMATIC | |
| Model | DC-0360 |
| Center Pin | Ø1.65 mm |
| Center Pin | Ø2.0 mm |
| Center Pin | Ø2.5 mm |

| | | | | | |
|------|--------------|--------|----------|--------|---------|
| 5 | Center pin | 1 | Brass | - | Tin |
| 4 | plain film | 1 | Brass | T=0.30 | Silver |
| 3 | illustration | 1 | Brass | T=0.30 | Silver |
| 2 | Contact | 1 | Brass | T=0.30 | Silver |
| 1 | Base | 1 | PBT | Black | - |
| ITEN | Name | Number | Material | Color | PLATING |

| | | | | | | | | | | | | |
|--|--|--|--|-------------|------|------------------------|--|--|-------------|------------------------------|-------|----------|
| | | | | ANGULAR | ±5° | SWITCH CONNECTOR | DSND | | SCALE: N/A | MODEL TYPE: DC POWER JACK | | |
| | | | | L ≤ 4 | ±0.2 | | DWN | | VIEW: | PART NO.: DC-0360-2.5 | | |
| | | | | 4 < L ≤ 16 | ±0.3 | | CHKD | | UNIT: mm/in | DWG NO.: | | |
| | | | | 16 < L ≤ 63 | ±0.4 | | APPD | | SIZE: A4 | | | |
| | | | | L > 63 | ±0.5 | | | | | | | |
| REVISIONS | | | | | | UNSPECIFIED TOLERANCES | | | | WEIGHT | SHEET | REVISION |
| | | | | | | | KE SI DA ELECTRONIC TECHNOLOGY CO., LTD | | | | 1/1 | A0 |
| WWW.BODONGKAIGUAN.NET WWW.CKJACK.COM WWW.KSDKG.COM | | | | | | | | | | | | |