

SPECIFICATION

Contact Rating: 50mA, 12V DC
 Contact Resistance: 100mΩ max
 Insulation Resistance: 100mΩ min. 500V DC
 Dielectric Strength: 250V AC/1minute
 Operating Temp: -30°C~+85°C
 Storage Temp: -30°C~+80°C
 Operating Temp: 100,000cycles

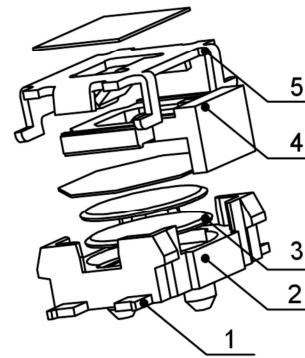

PAPT NO	TS-1186F-X-X
Operating Force	B:160gf C:260gf
Height	H:3.6
Fixed column	A:With B:Without

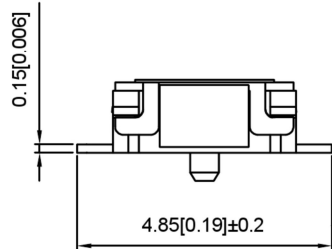
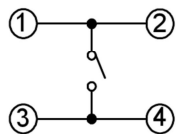

CIRCUIT DIAGRAM

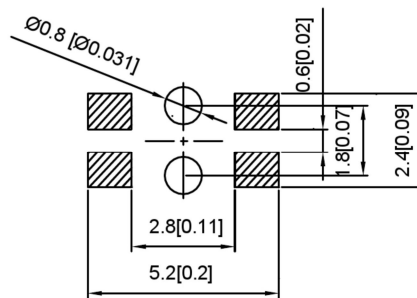

PCB LAND DIMENSION

ITEM	PAPT NAMF	TER,NO	QTY	MATERIAL	FINISHING	REMARK
⑤	Cover	—	1	SUS		
④	Keystake	—	1	Pa46	Black	
③	Contact	—	1	F.ag/Sus		
②	Housing	—	1	LCP	Black	
①	Terminal	—	1	Brass (0.30t)	Plating silvering	

				ANGLAR	±5°		DSND		SCALE: N/A	MODEL TYPE: TACT SWITCH			
				L ≤ 4	±0.2		DWN		VIEW:	PART NO.: TS-1186F-X-X			
				4 < L ≤ 16	±0.3		CHKD		UNIT: mm/in	DWG NO.:			
				16 < L ≤ 63	±0.4		APPD		SIZE: A4				
				L > 63	±0.5					WEIGHT	SHEET	REVISI	
				UNSPECIFIED TOLERANCES			KE SI DA ELECTRONIC TECHNOLOGY CO., LTD					1/1	A0
DATE				REVISED	APPROVED	WWW.BODONGKAIGUAN.NET WWW.CKJACK.COM WWW.KSDKG.COM							