

PCB LAYOUT PLAN

Rated range:50mA DC12V  
 Insulation resistance:≥100MΩmin (DC100V)  
 Compressive strength:AC100V(50/60Hzfoy1minute)  
 Mechanical life:50000 cycles  
 Operating temperature:-10℃~+60℃  
 Operation strength:50±30gf

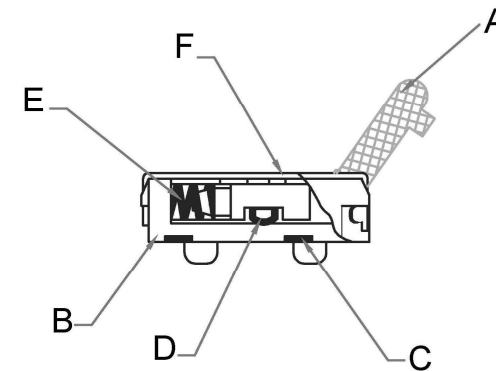

|      |               |     |                 |               |
|------|---------------|-----|-----------------|---------------|
| F    | lid           | 1   | SUS             | silvery white |
| E    | Shrapnel      | 1   | SUS             | silvery white |
| D    | Contact plate | 1   | PPA             | black         |
| C    | Solder patch  | 1   | Phosphor bronze | silvery white |
| B    | base          | 1   | PPA             | black         |
| A    | Button        | 1   | PA66            | wihte         |
| ITEM | PAPT NAMF     | QTY | Material        | Colour        |

|                       |  |  |  |                        |      |   |      |  |             |                            |       |          |
|-----------------------|--|--|--|------------------------|------|---|------|--|-------------|----------------------------|-------|----------|
|                       |  |  |  | ANGLAR                 | ±5°  | <br>SWITCH CONNECTOR                    | DSND |  | SCALE: N/A  | MODEL TYPE:<br>TACT SWITCH |       |          |
|                       |  |  |  | L ≤ 4                  | ±0.2 |   | DWN  |  | VIEW:       | PART NO.:<br>TM-1201-X     |       |          |
|                       |  |  |  | 4 < L ≤ 16             | ±0.3 |   | CHKD |  | UNIT: mm/in | DWG NO.:                   |       |          |
|                       |  |  |  | 16 < L ≤ 63            | ±0.4 |   | APPD |  | SIZE: A4    |                            |       |          |
|                       |  |  |  | L > 63                 | ±0.5 |   |      |  |             | WEIGHT                     | SHEET | REVISION |
| REVISIONS             |  |  |  | UNSPECIFIED TOLERANCES |      | KE SI DA ELECTRONIC TECHNOLOGY CO., LTD |      |  |             | 1/1                        | A0    |          |
| WWW.BODONGKAIGUAN.NET |  |  |  | WWW.CKJACK.COM         |      |   |      |  |             |                            |       |          |
|                       |  |  |  |                        |      |   |      |  |             |                            |       |          |