

Circuit diagram

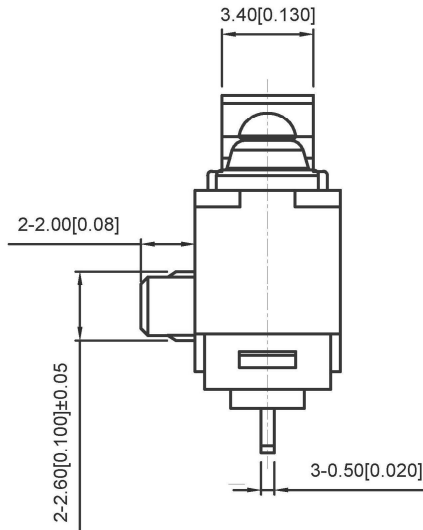

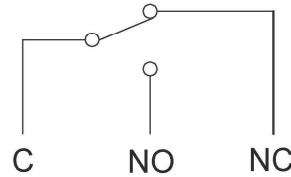

Technical Parameters

1. Electrical Rating: 0.1A 125/250VAC
3A/12VDC; 0.1A/48VDC
2. Electrical lifetime: 100 000
3. Mechanical lifetime: 100 000
4. Contact Resistance: ≤50mΩ
5. Operating force: 2.2N MAX
6. Pretravel: 3.0mm MAX
7. Withstand Voltage: Feet and Feet 500V/5S/5mA
Feet and Shell 1500/5S/5mA
8. Insulation Resistance: ≥100MΩ (Test Voltage 500VDC)
9. Proof Tracking Index (PTI): 175V
10. Ambient temperature: 40T85°
11. Operation Position: 7.1±0.5

| | | |
|---|------------------------|--------------|
| 1 | Rubber shell | PA66 |
| 2 | seal ring | Silica gel |
| 3 | base | Brass+PA66 |
| 4 | According to sincerity | POM |
| 5 | Contact moving plate | C5191+AgNi10 |
| 6 | Strut | SUS301-H |

Waterproof grade: IP67

| | | | | | | | | | | | | |
|-----------------------|--|--|--|------------------------|------|---|------|--|---|-------------|---------------|----------|
| | | | | ANGLAR | ±5° |  SWITCH CONNECTOR | DSND | | SCALE: N/A | MODEL TYPE: | Microswitch | |
| | | | | L ≤ 4 | ±0.2 | | DWN | | VIEW:  | PART NO.: | DF1-1365UNZ-1 | |
| | | | | 4 < L ≤ 16 | ±0.3 | | CHKD | | UNIT: mm/in | DWG NO.: | | |
| | | | | 16 < L ≤ 63 | ±0.4 | | APPD | | SIZE: A4 | | | |
| | | | | L > 63 | ±0.5 | | | | | WEIGHT | SHEET | REVISION |
| REVISIONS | | | | UNSPECIFIED TOLERANCES | | KE SI DA ELECTRONIC TECHNOLOGY CO., LTD | | | | | 1/1 | A0 |
| WWW.BODONGKAIGUAN.NET | | | | WWW.CKJACK.COM | | WWW.KSDKG.COM | | | | | | |