

DIMENSIONS

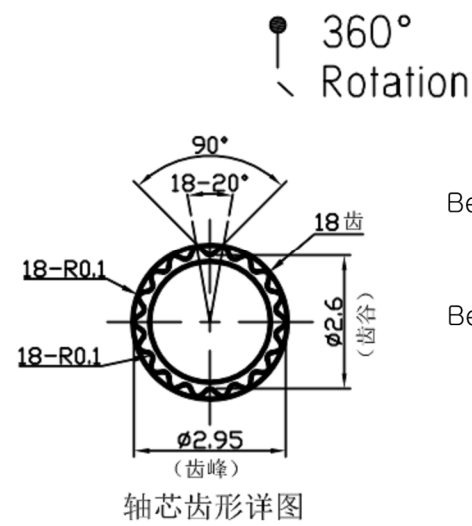

(SW01) ENCODER
(SW02) PUSH ON SW
CLICK Position

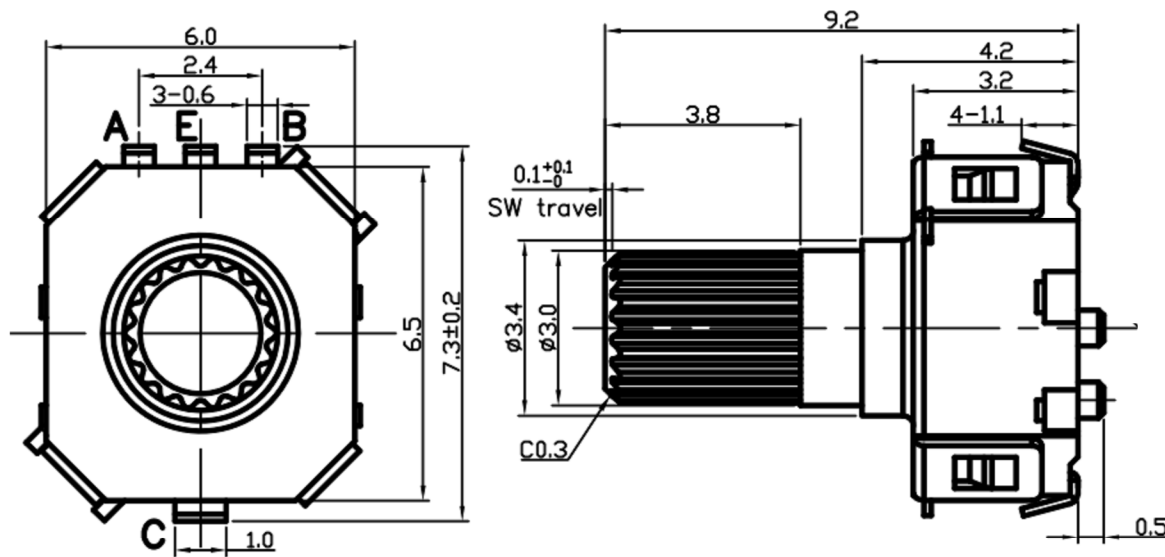
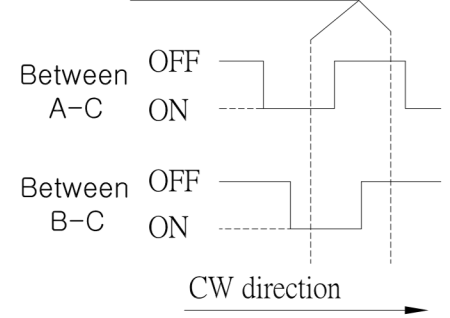

(SW01) OUTPUT
(SW02) CIRCUIT DIAGRAM

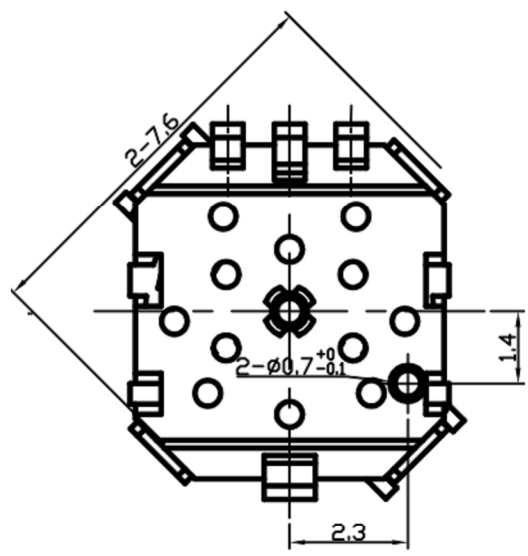
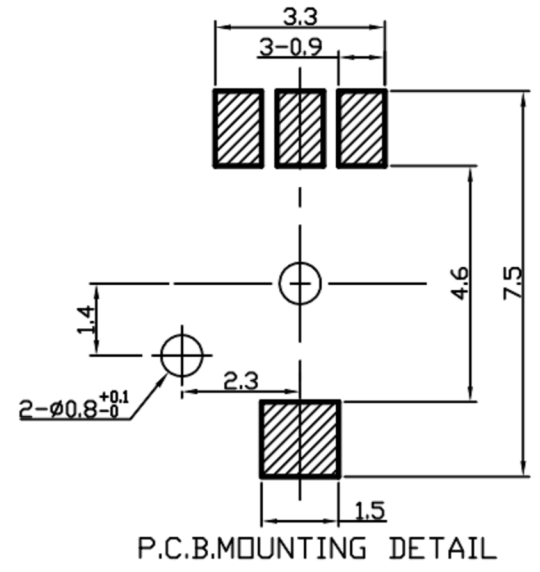
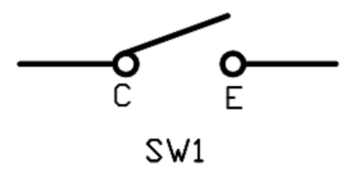

EC06 SERIES ROTARY ENCODER
EC06 编码器

Electrical characteristics 电气特性	
Rating Power 额定功率	DC5V 10mA
Fluttering 振荡	T1,T3≤5ms
Sliding Noise(Bounce)滑动杂音	T2≤2ms
Dielectric Voltage 耐电压	For 1 minute or more AC 300V
Insulation resistance 绝缘阻抗	More than 10MQ at DC 250V
Phase Difference 相位差	ΔT=0.15T±0.1T

Mechanical characteristics 机械特性	
Total Rotational Angle 旋转角度	360°
Rotational Torque 旋转力矩	10gf.cm~100 gf.cm
Number of click 段位数量	12 Detents(Angle:30°±3°)

Environmental characteristics	
Rotational Life 旋转寿命	30,000 cycles

广东科斯达电子科技有限公司
KSDKG Guang dong Keside Electronic Technology Co., Ltd.

TOLERANCE UNLESS OTHERWISE STATED:
Up to 5 ±0.2
Above 5 ~ 15 ±0.3
Above 15 ~ 30 ±0.4
Above 30 ~ 50 ±0.5
Angle ±0.3°

3RD. ANGEL'S

UNITS MM

DRAWN BY: Jack Lu 07/23/13
CHECKED BY: Jacky Chen 07/23/13
APPROVED BY: Tony Kao 07/23/13

MAT'L	TITLE	EC ENCODING SWITCH
FINISH	MODLE	EC编码开关系列
SCALE 1 : 1	DWG NO.	KSD-EC0601S-A2
SHEET NO. 1 of 1	PART NO.	

SIZE A4
VER R2

ITEM NO.	DESCRIPTION	DRAWN	DATE
2	公差及料號更新	Jack	072313
1	圖面更新	Frank Wu	021012