

DIMENSIONS

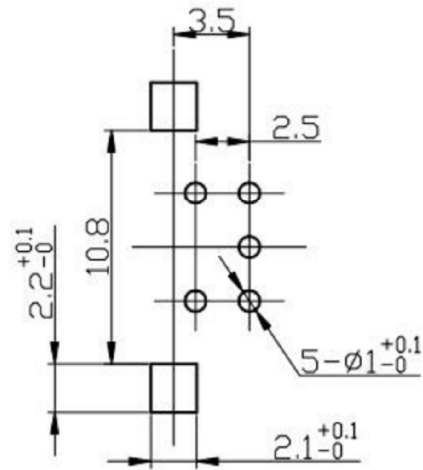

P.C.BOARD MOUNTING HOLE DIMENSIONS

**(SW01) ENCODER
(SW02) PUSH ON SW
CLICK Position**

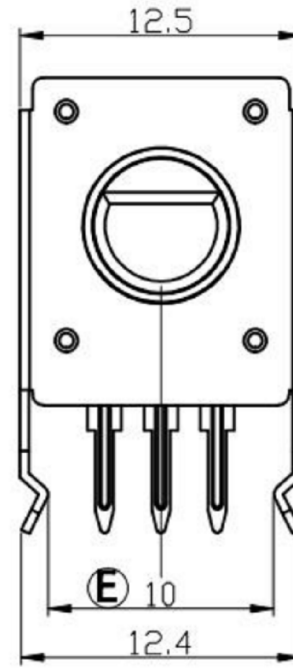
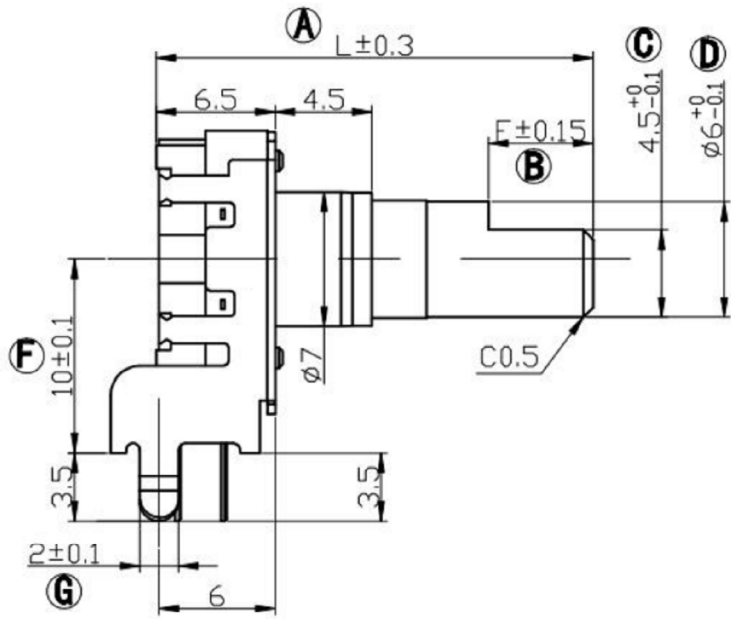
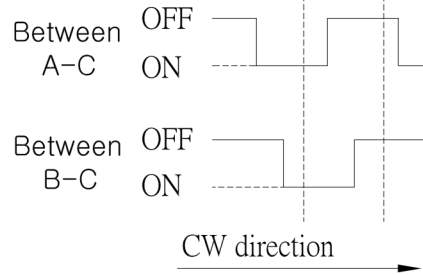

(SW01) OUTPUT

Electrical characteristics 电气特性	
Rating Power 额定功率	DC5V 10mA
Fluttering 振荡	T1,T3≤3ms
Sliding Noise(Bounce)滑动杂音	T2≤2ms
Dielectric Voltage 耐电压	For 1 minute or more AC 300V
Insulation resistance 绝缘阻抗	More than 100MΩ at DC 250V
Phase Difference 相位差	ΔT≥0.08T
Mechanical characteristics 机械特性	
Total Rotational Angle 旋转角度	360°
Rotational Torque 旋转力矩	30gf.cm~200 gf.cm
Number of click 段位数量	30 Detents(Angle:1.2°±2°) 20 Detents(Angle:1.8°±2°)
Push-Pull Strength 轴推拉强度	10Kgf.cm Min for 10Sec
Bushing & nut tight strength 轴套锁紧强度	10.0Kgf Min
Switch Specifications 开关特性	
Maximum Ratings 额定电压	DC5V 10mA(1mA Min)
Contact resistance 接触阻抗	200mΩ Max
Travel of switch 开关移动量	0.5+0.4/-0.3 mm OR 1.5+0.4/-0.3 mm
Operating force of switch 开关动作力	500±200gf
Environmental characteristics	
Rotational Life 旋转寿命	30,000 cycles
Switch Life 开关寿命	20,000 cycles

(SW02)CIRCUIT DIAGRAM

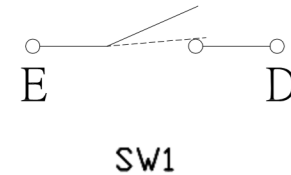

EC11 轴心轴套规格

F-TYPE	D=3.5	D=5	D=7	D=10	Y-TYPE	D=3.5	D=5	D=7	D=10
	L 9, 9, 10 F 3, 4, 4	L 10, 12, 5, 13, 15, 3, 16, 7 F 4, 6, 7, 5, 7	L 12, 5, 13, 15, 17, 3, 20 F 4, 4, 5, 7, 7	L 29, 3, 32 F 9, 12		L 8, 5 F 3, 5	L 9, 5, 11, 11, 3, 12, 5 F 4, 4, 5, 5, 5	L 12, 5, 13, 5, 15, 5 F 4, 5, 5	L 19, 5 F 6

输出信号

轴的旋转方向 Shaft rotational direction	信号 Signal	正向 Direction	反向 Reverse
顺时针方向 C.C.W.	A(A`C端子间) A(Terminal A`C)		
逆时针方向 C.C.W.	B(B`C端子间) B(Terminal B`C)		

* 具体轴心规格，可依客户需求订做。
Specific axis specifications can be customized according to customer needs.

广东科斯达电子科技有限公司
KSDKG Guang dong Keside Electronic Technology Co., Ltd.

TOLERANCE UNLESS OTHERWISE STATED :
Up to 5 ±0.2
Above 5 ~ 15 ±0.3
Above 15 ~ 30 ±0.4
Above 30 ~ 50 ±0.5
Angle ±0.3°

3RD. ANGEL'S



UNITS MM

DRAWN BY: Jack Lu	DATE: 07/23/13	MAT'L	TITLE: EC ENCODING SWITCH
CHECKED BY: Jacky Chen	DATE: 07/23/13	FINISH	MODLE: EC编码开关系列
APPROVED BY: Tony Kao	DATE: 07/23/13	SCALE: 1 : 1	DWG NO.: KSD-EC1201S
		SHEET NO.: 1 of 1	PART NO.
			SIZE: A4
			VER: R2