

**DIMENSIONS**

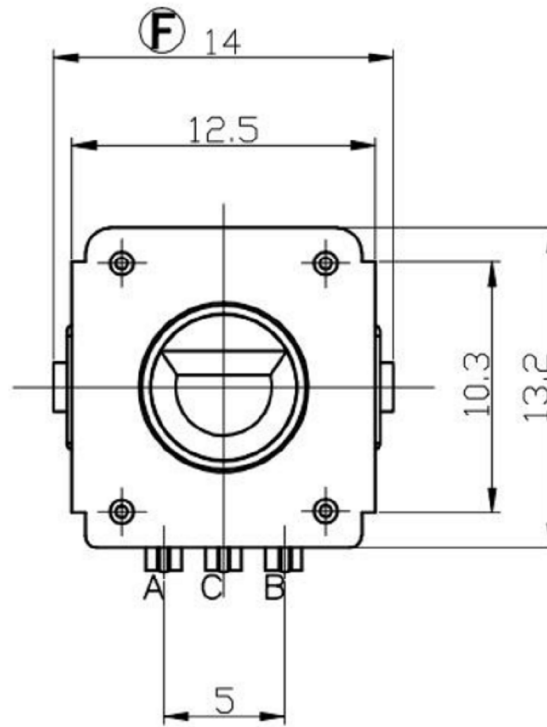

(SW01) ENCODER  
(SW02) PUSH ON SW  
CLICK Position

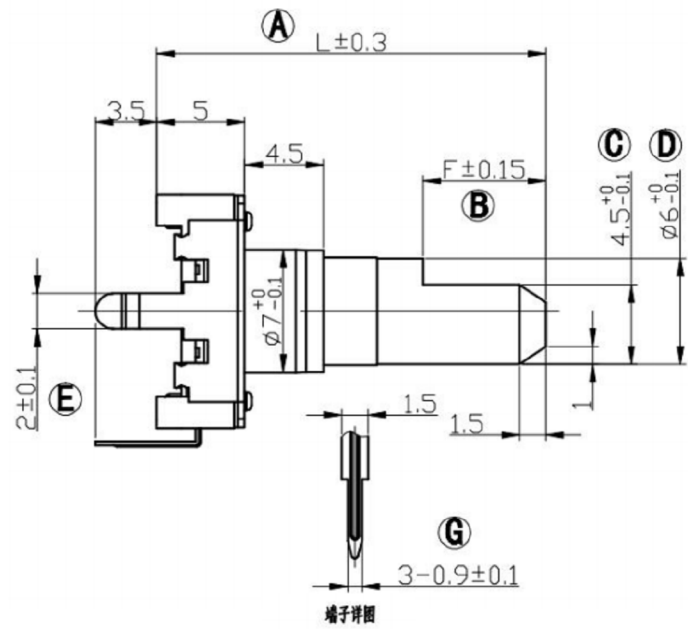
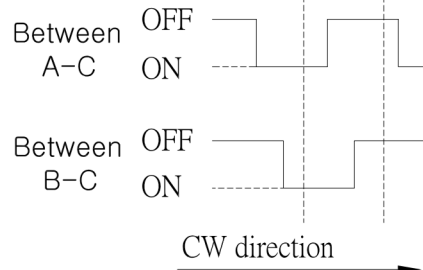

(SW01) OUTPUT

Electrical characteristics 电气特性	
Rating Power 额定功率	DC5V 10mA
Fluttering 振荡	T1,T3≤3ms
Sliding Noise(Bounce)滑动杂音	T2≤2ms
Dielectric Voltage 耐电压	For 1 minute or more AC 300V
Insulation resistance 绝缘阻抗	More than 100MΩ at DC 250V
Phase Difference 相位差	ΔT≤0.08T
Mechanical characteristics 机械特性	
Total Rotational Angle 旋转角度	360°
Rotational Torque 旋转力矩	30gf.cm~200 gf.cm
Number of click 档位数量	30 Detents(Angle:1.2°±2°) 20 Detents(Angle:1.8°±2°)
Push-Pull Strength 轴推拉强度	10Kgf.cm Min for 10Sec
Bushing & nut tight strength 轴套锁紧强度	10.0Kgf Min
Switch Specifications 开关特性	
Maximum Ratings 额定电压	DC5V 10mA(1mA Min)
Contact resistance 接触阻抗	200mΩ Max
Travel of switch 开关移动量	0.5+0.4/-0.3 mm OR 1.5+0.4/-0.3 mm
Operating force of switch 开关动作力	500±200gf
Environmental characteristics	
Rotational Life 旋转寿命	30,000 cycles
Switch Life 开关寿命	20,000 cycles

(SW02)CIRCUIT DIAGRAM

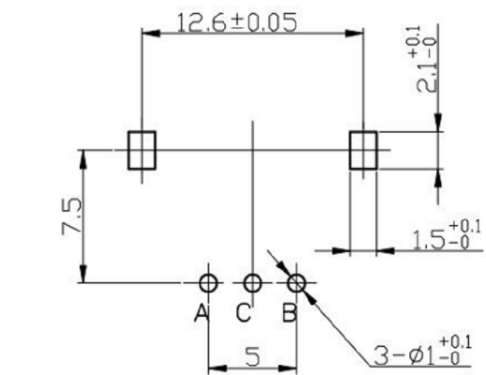
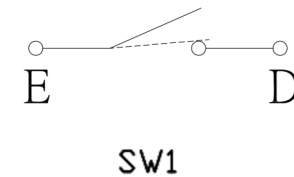

P.C.BOARD MOUNTING HOLE DIMENSIONS

EC11 轴心轴套规格

F-TYPE	D=3.5	D=5	D=7	D=10	Y-TYPE	D=3.5	D=5	D=7	D=10
	L 9 10 F 3 4	L 10 12 13 15 16 7 F 4 6 7 5 7	L 12 13 15 17 20 F 4 5 7 7	L 29 3 32 F 9 12		L 8 5 F 3 5	L 9 5 11 11 3 12 5 F 4 4 5 5 5	L 12 5 13 5 15 5 F 4 5 5	L 19 5 F 6

输出信号

轴的旋转方向 Shaft rotational direction	信号 Signal	正向 Direction	反向 Reverse
顺时针方向 C.C.W.	A(A`C端子间) A(Terminal A`C)		
逆时针方向 C.C.W.	B(B`C端子间) B(Terminal B`C)		

\* 具体轴心规格，可依客户需求订做。  
Specific axis specifications can be customized according to customer needs.

ITEM NO.	DESCRIPTION	DRAWN	DATE
2	公差及料號更新	Jack	072313
1	圖面更新	Frank Wu	021012

**广东科斯达电子科技有限公司**  
KSDKG Guang dong Keside Electronic Technology Co., Ltd.

TOLERANCE UNLESS OTHERWISE STATED:  
Up to 5 ±0.2  
Above 5 ~ 15 ±0.3  
Above 15 ~ 30 ±0.4  
Above 30 ~ 50 ±0.5  
Angle ±0.3°

3RD. ANGEL'S



UNITS MM

DRAWN BY: Jack Lu	DATE: 07/23/13	MAT'L	TITLE: EC ENCODING SWITCH
CHECKED BY: Jacky Chen	DATE: 07/23/13	FINISH	MODLE: EC编码开关系列
APPROVED BY: Tony Kao	DATE: 07/23/13	SCALE: 1 : 1	DWG NO.: KSD-EC1202
		SHEET NO.: 1 of 1	PART NO.
			SIZE: A4
			VER: R2