

KSC V2 Series Side Actuated Sealed Tact Switch



Features/Benefits

- Full SMD side actuated
- Haptic adaptability
- Pin in paste terminations
- Tape & reel
- IP67

Typical Applications

- Automotive
- Industrial electronics
- Network equipment
- Telecommunications

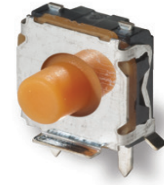

Tactile Switches

Specification

FUNCTION: momentary action
 CONTACT ARRANGEMENT: 1 make contact = SPST, N.O.
 TERMINALS:
 2 pin in paste signal terminals
 3 SMD ground terminals

Mechanical

Type	Force (N)	Operating Life (operations)	Travel (mm)
KSC201 V2 LFS	1.6 ± 0.6	1,000,000	0.3 ± 0.2
KSC421 V2 70SH LFS	1.55 ± 0.45	300,000	0.45 ± 0.25
KSC441V2 70SH SP DELTA LFS	3.5 ± 1.0	300,000	0.7 ± 0.2
KSC443V2 70SH SP DELTA LFG	3.5 ± 1.0	300,000	0.7 ± 0.2
KSC421 V2 RT LFS	1.8 ± 0.5	300,000	0.3 ± 0.2
KSC423 V2 RT LFG	1.8 ± 0.5	300,000	0.3 ± 0.2
KSC441 V2 RT LFS	3.4 ± 1.0	300,000	0.35 ± 0.2

Electrical

	Silver	Gold
MAXIMUM POWER:	1 VA	0.2 VA
MAXIMUM VOLTAGE:	32 VDC	32 VDC
MINIMUM VOLTAGE:	20 mV	20 mV
MAXIMUM CURRENT:	50 mA	10 mA
MINIMUM CURRENT:	1 mA	0.1 mA

DIELECTRIC STRENGTH (50 Hz, 1 min.): ≥ 250 Vrms
 CONTACT RESISTANCE: ≤ 100 mΩ
 INSULATION RESISTANCE (100 V, initial stage): > 10⁹ Ω
 BOUNCE TIME: < 1 ms

Environmental

	Silver	Gold
OPERATING TEMPERATURE:	-40°C to 85°C	-40°C to 125°C
STORAGE TEMPERATURE:	-55°C to 85°C	-55°C to 125°C

Process

SOLDERING: Depending on the application, this component is suited to the following methods:

- Cleaning according to typical washing processes.
- Lead free reflow soldering process in accordance with IEC 61760-1.

TERMINALS: pin in paste, silver or gold plated
 TOP PLATE: tin plated
 MSL level: 1
 Vacuum pick head mandatory

Packaging

In reels of 800 pieces.
 Dimensions of reels according to EIA RS481 or IEC 2863.
 External diameter 380 mm ± 2 mm.

NOTE: This product is designed and manufactured for general electronic devices. For systems where reliability and safety are required, please contact your sales representative to secure product integration and function to secure usage.

NOTE: Other configurations of haptics are available upon demand

MISUSE OVERLOAD: 40N with back support
 SHEAR FORCE: 10N without back support

How To Order

Our easy build-a-switch concept allows you to mix and match options to create the switch you need. To order, select desired option from each category and place it in the appropriate box.

For any part number different from those listed above, please consult your local representative.

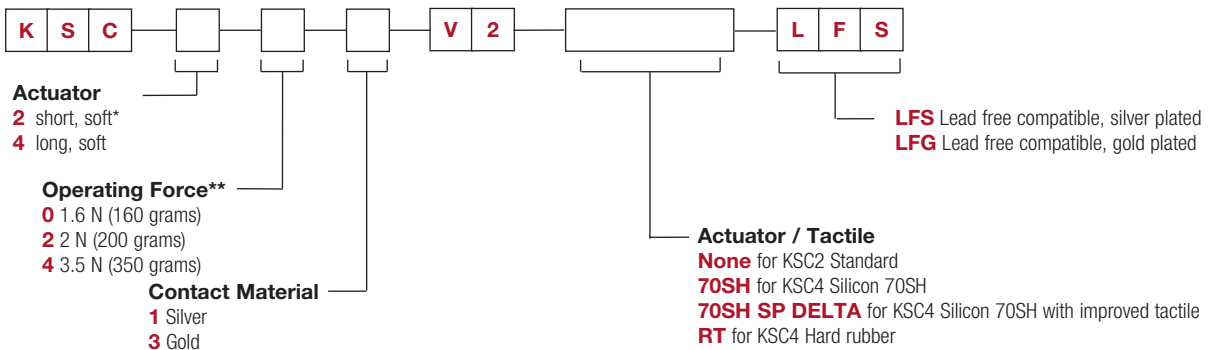

* KSC2 version available upon demand
 ** Force available upon demand (variant version)

Dimensions are shown: mm
 Specifications and dimensions subject to change

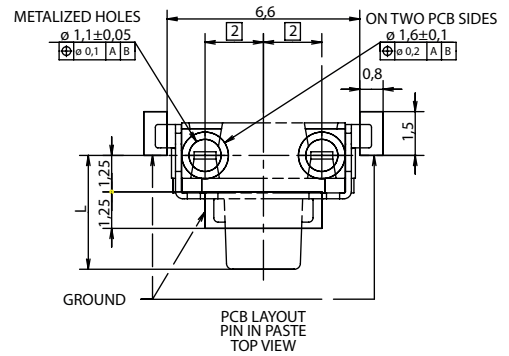
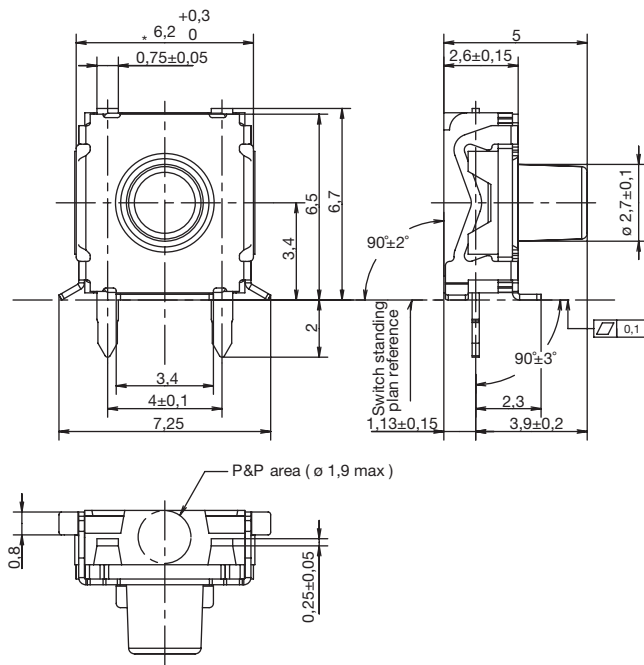

Series	L
KSC2	2,3
KSC4	3,9

IMPORTANT NOTE FOR RT ACTUATOR

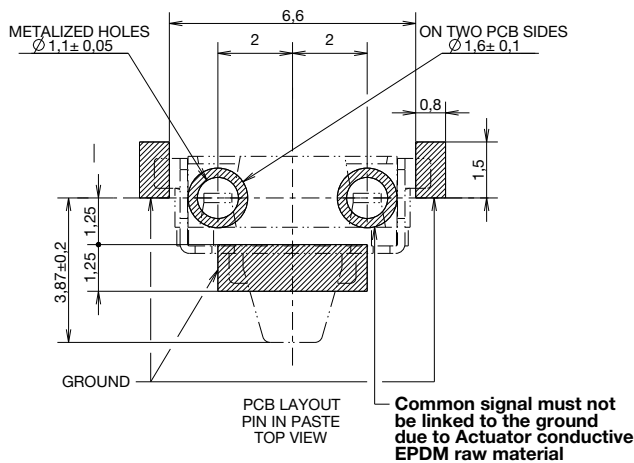

This actuator is not compatible with grease even with restricted contact.

In case of the integration of an actuator or button by the customer, please consult us if use of plasticizer agent for button raw material (risk of chemical migration).

Our actuator contains carbon particles and is electrical conductive. In consequence, customer actuator must be electric insulating raw material.

Due to the cover raw material plating, small tin balls can appear after the reflow soldering process. These small tin balls are located near all cutting areas.



TAPE AND REEL

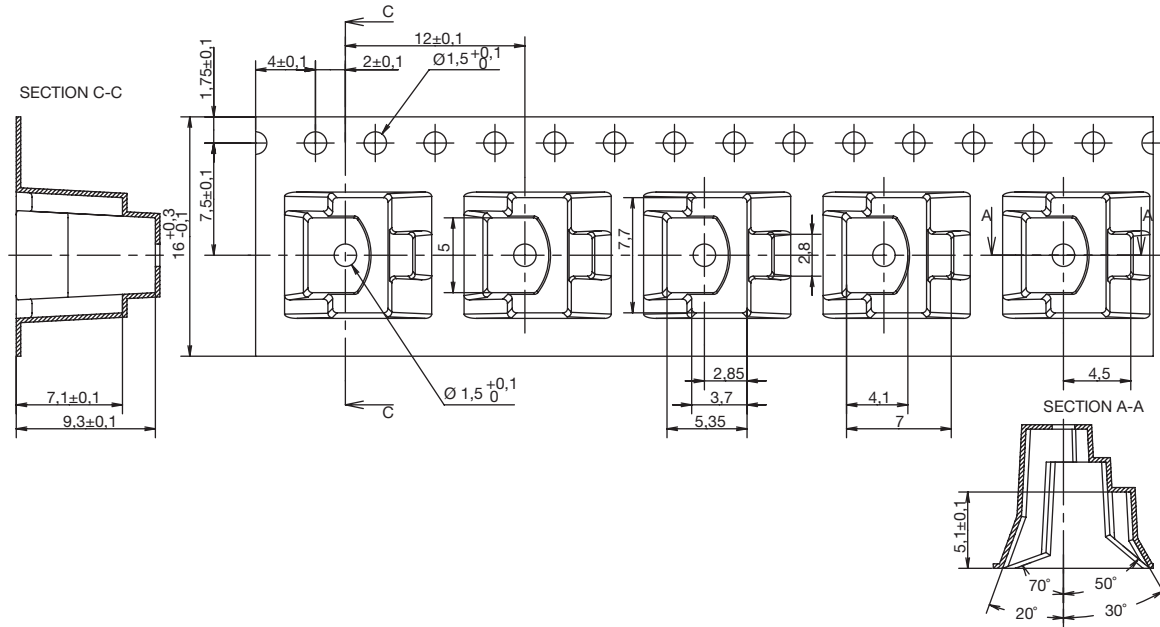

INTEGRATION

