

KSD-SAMXD Series Dust Protected Seat Adjustment Switches

New

KSD
SWITCH CONNECTOR

Features/Benefits

- Multi-directional 2 & 4 ways
- Power handling for motor direct drive
- IP5x
- THT terminations

Typical Applications

- Seat adjustment module for passenger cars & commercial vehicles
- Industrial joystick



P/N	Description		Actuator Position	Actuator Shape	Spring Pin	Cycles	Operating Force (N)	Travel (mm)
SAMXDH2LR14SP	SAM XD 2W LR Switch	2 way	Left	Round	Yes	30,000	5.3 ± 1.5	1.3 ± 0.4
SAMXDH2LR10SP	SAM XD 2W LR Switch	2 way	Left	Round	Yes	30,000	6.0 ± 1.75	1.0 ± 0.4
SAMXDH2LR10	SAM XD 2W LR Switch	2 way	Left	Round	No	30,000	6.0 ± 1.75	1.0 ± 0.4
SAMXDH2LS11	SAM XD 2W LS Switch	2 way	Left	Square	No	30,000	6.0 ± 1.75	1.0 ± 0.4
SAMXDH2MR14SP	SAM XD 2W MR Switch	2 way	Middle	Round	Yes	30,000	5.3 ± 1.5	1.3 ± 0.4
SAMXDH2MR10SP	SAM XD 2W MR Switch	2 way	Middle	Round	Yes	30,000	6.0 ± 1.75	1.0 ± 0.4
SAMXDH4MR11SP	SAM XD 4W MR Switch	4 way	Middle	Round	Yes	30,000	6.0 ± 1.75	1.2 ± 0.4
SAMXDH4MS11	SAM XD 4W MR Switch	4 way	Middle	Square	No	30,000	6.0 ± 1.75	1.2 ± 0.4

Specifications

FUNCTION: Momentary action
CONTACT ARRANGEMENT: SPDT per switching circuit
SWITCHING MODE: Non-Shorting
TERMINALS: THT - Through Hole Terminals

Electrical

RATING: 15A @ 14V DC
INITIAL CONTACT RESISTANCE: <50mΩ per switching circuit
JUMP START: 26VDC for 1 minute
OVER VOLTAGE: 18VDC for 60 minute at 65°C
OVER CURRENT: 30A at 14V for 10 minute
BOUNCE TIME: <10ms

Environmental

OPERATING TEMPERATURE: -40°C to +85°C
SEALING LEVEL: IP5x

How To Order

Our easy build-a-switch concept allows you to mix and match options to create the switch you need. To order, select desired option from each category and place it in the appropriate box.

For any part number different from those listed above, please consult your local representative.

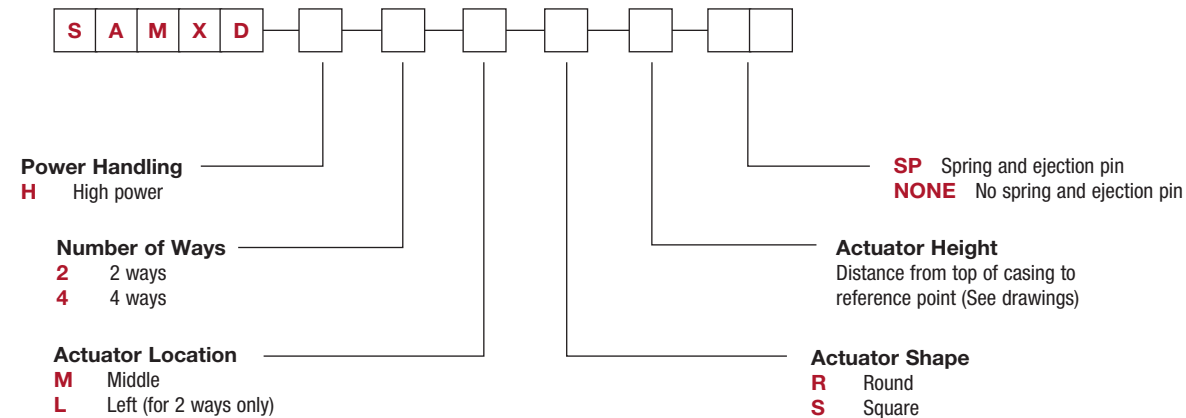

Dimensions are shown: mm
Specifications and dimensions subject to change



KSD-SAMXDH2LR10

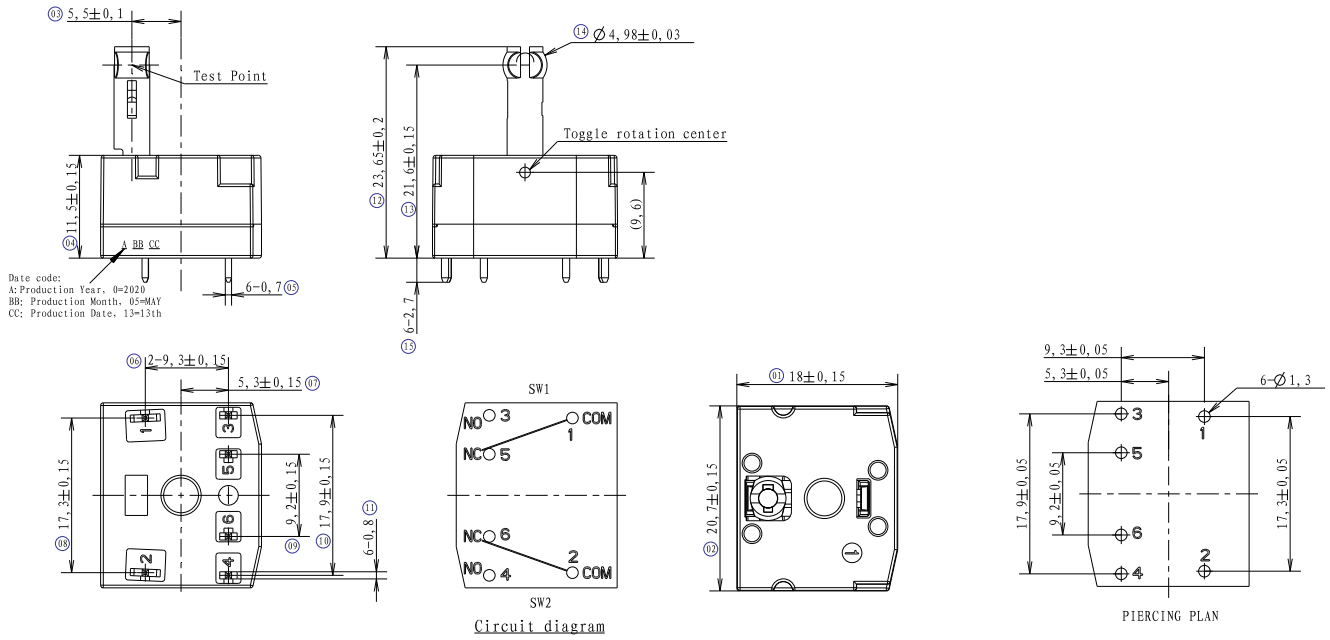

KSD-SAMXDH2LR10SP

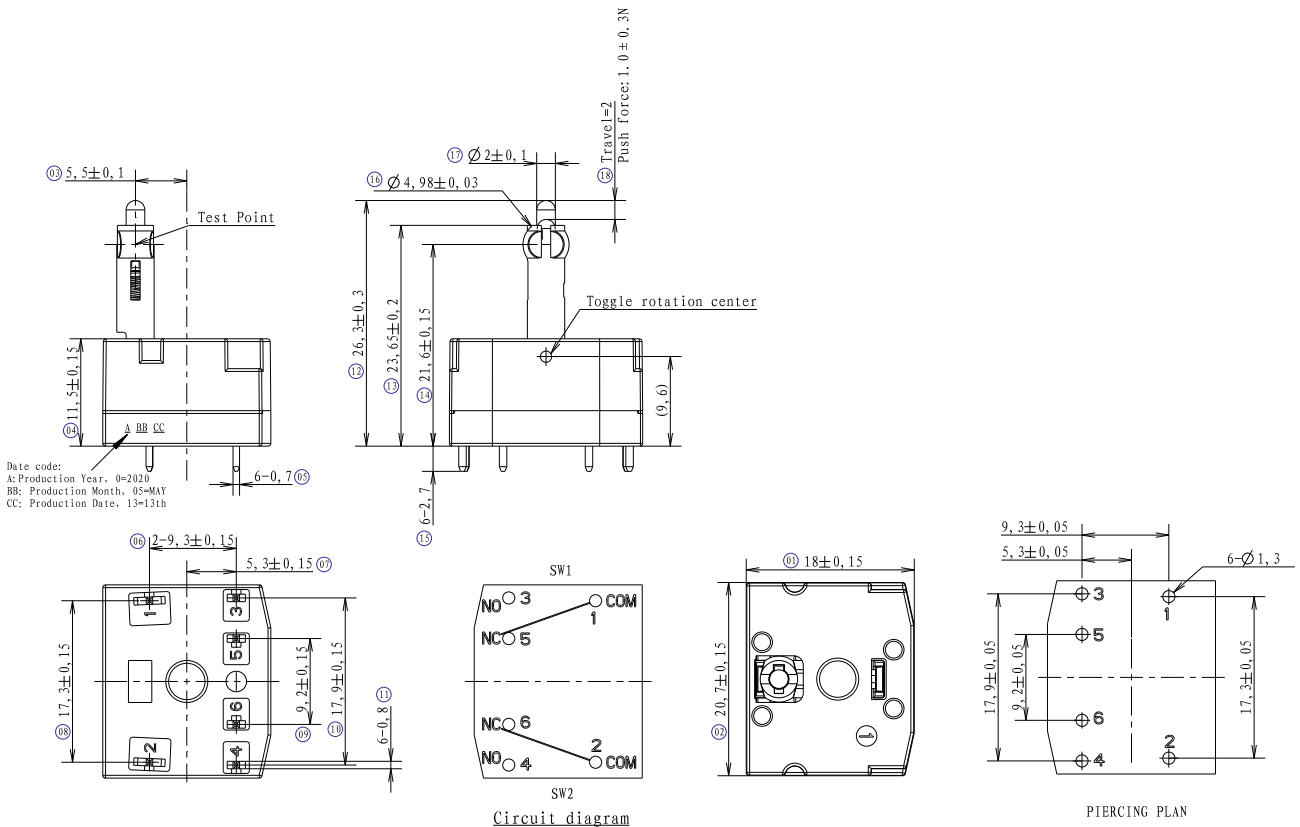

Dimensions are shown: mm
Specifications and dimensions subject to change

SAMXD Series Dust Protected Seat Adjustment Switches

SAMXDH2LR14SP

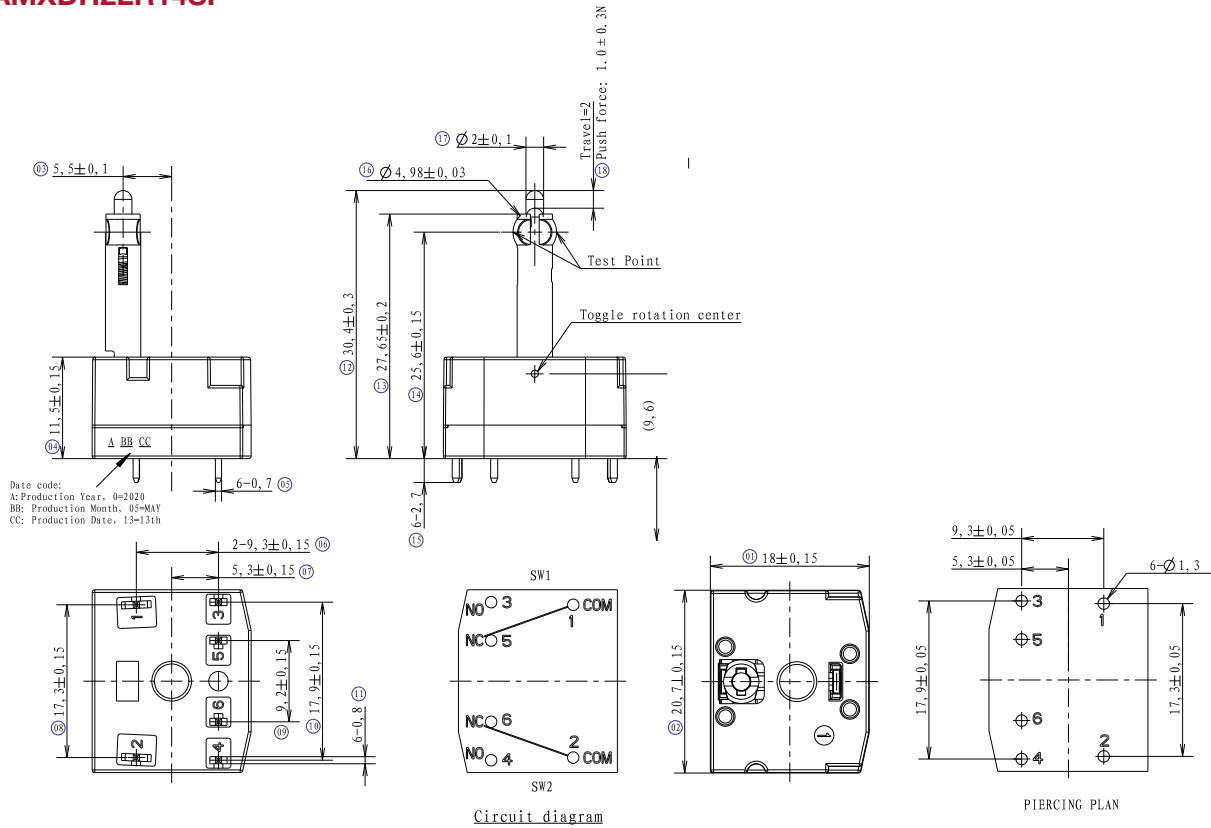

Date code:
A: Production Year, 0=2020
BB: Production Month, 05=MAY
CC: Production Date, 13=13th

SAMXDH2LS11

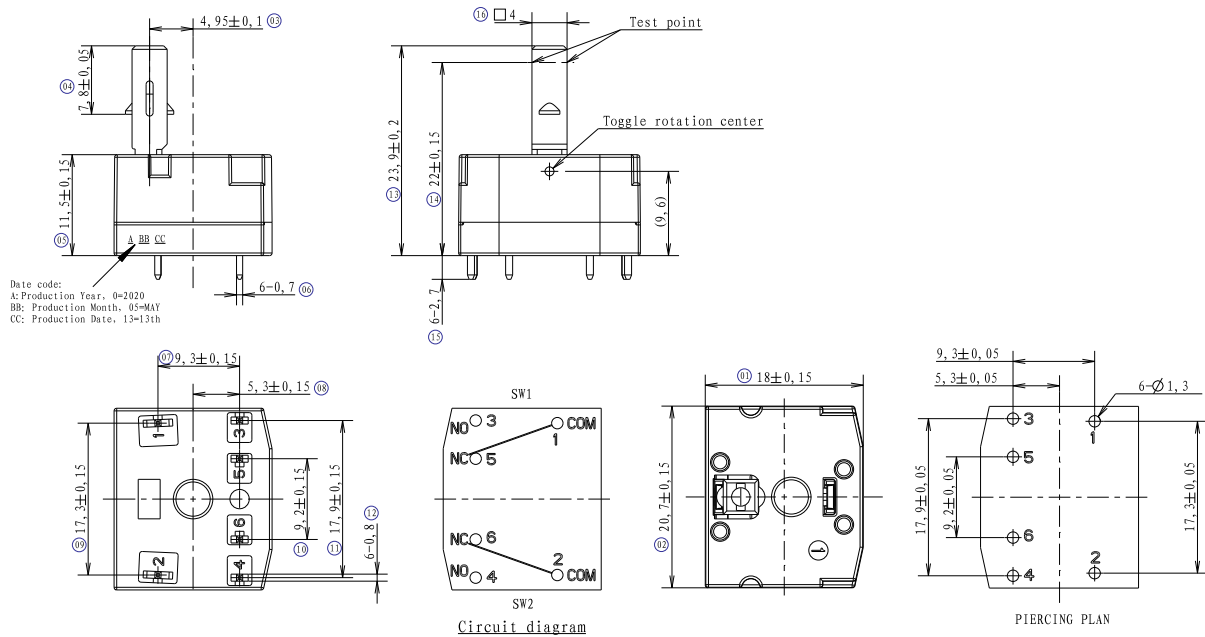

Date code:
A: Production Year, 0=2020
BB: Production Month, 05=MAY
CC: Production Date, 13=13th

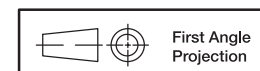

Dimensions are shown: mm
Specifications and dimensions subject to change



KSD-SAMXDH2MR10SP

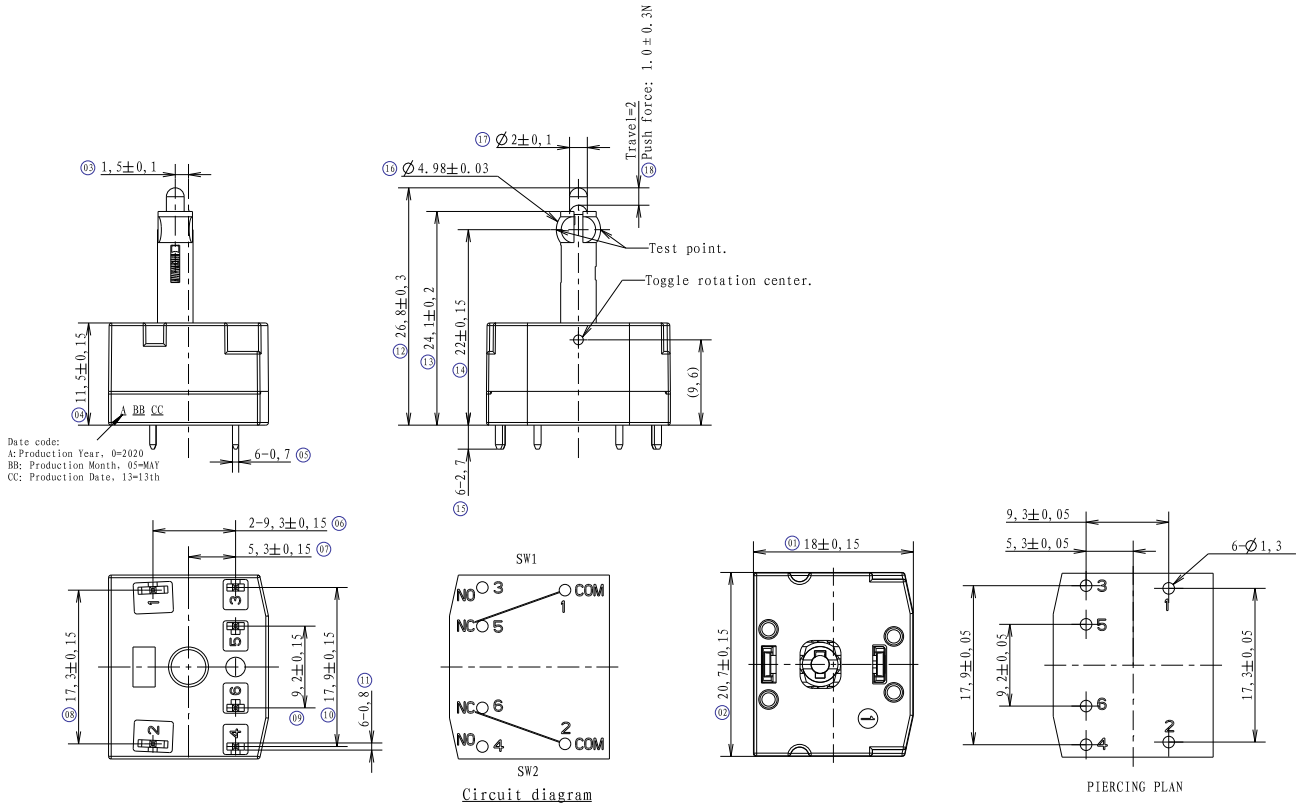

KSD-SAMXDH2MR14SP

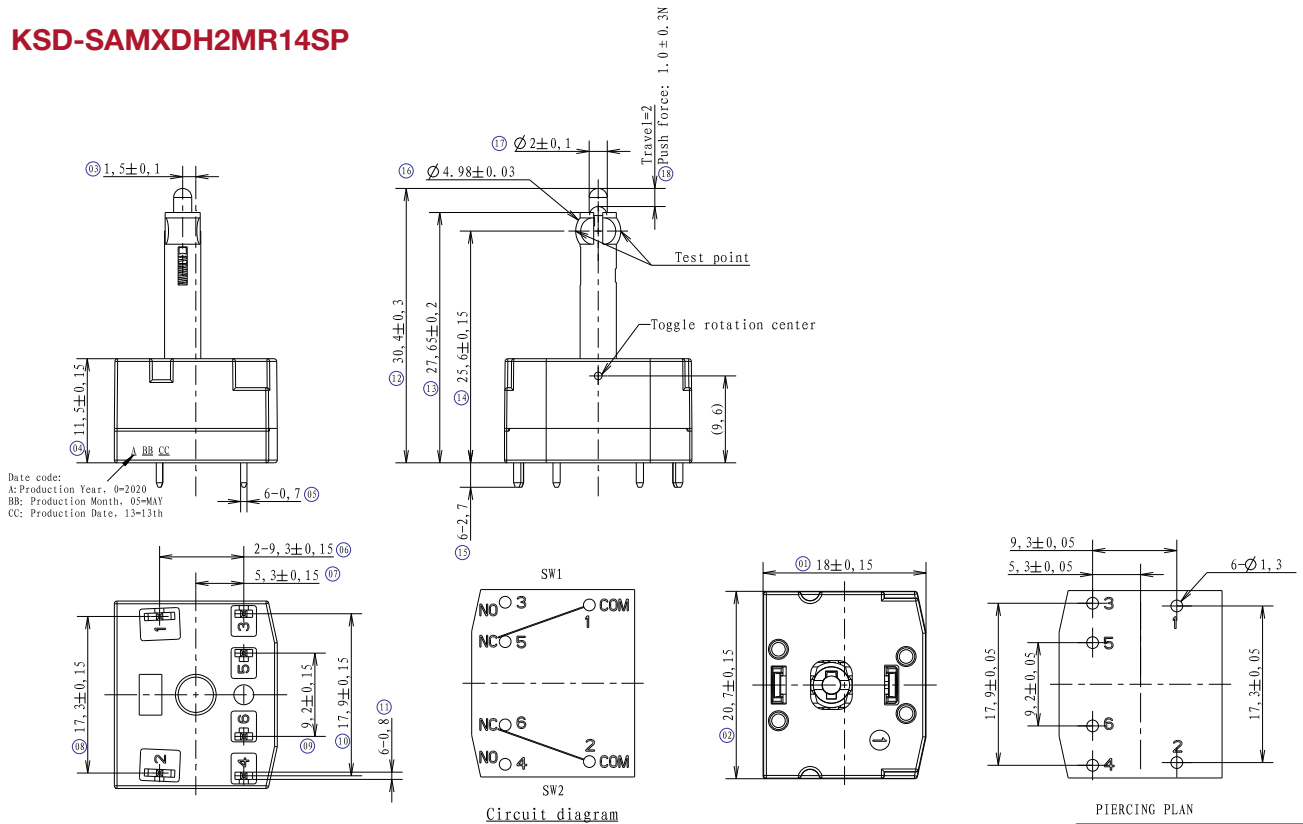

Dimensions are shown: mm
Specifications and dimensions subject to change

KSD-SAMXD Series Dust Protected Seat Adjustment Switches

New

KSD
SWITCH CONNECTOR

SAMXDH4MR11SP

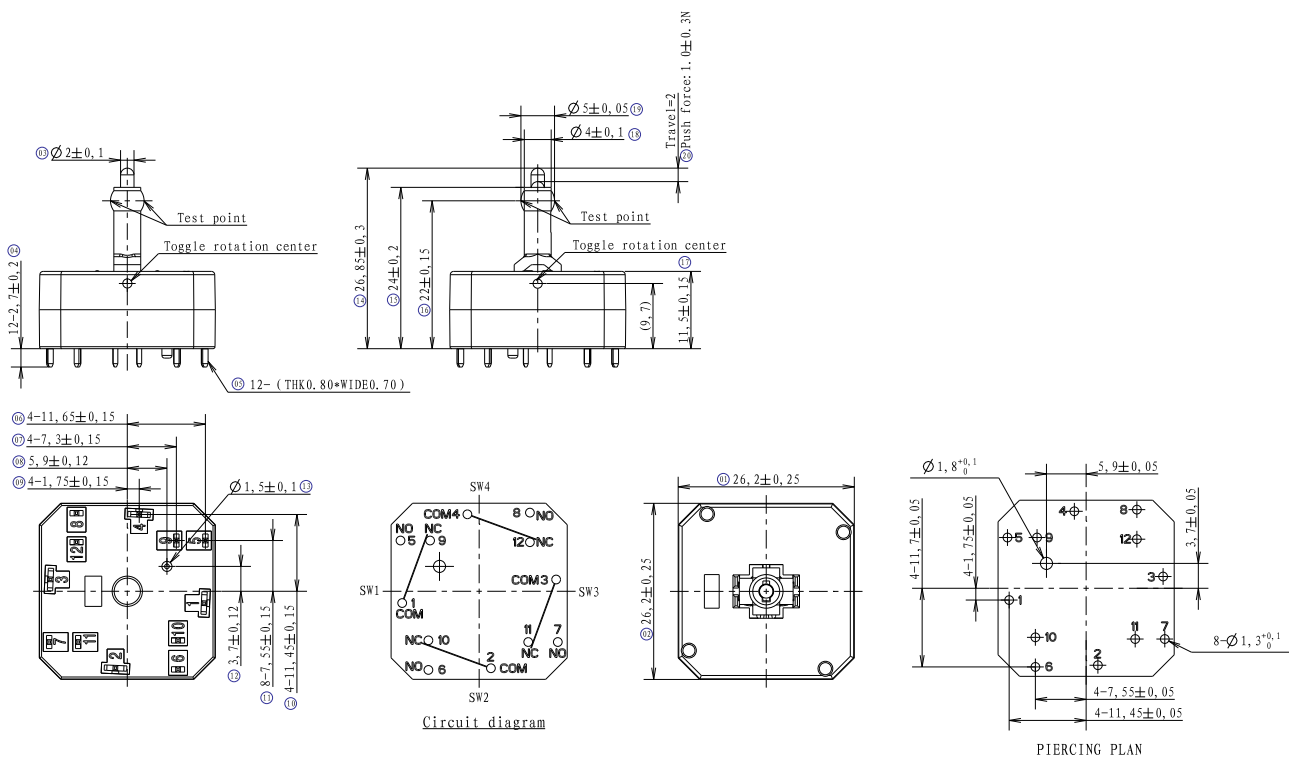

KSD-SAMXDH4MS11

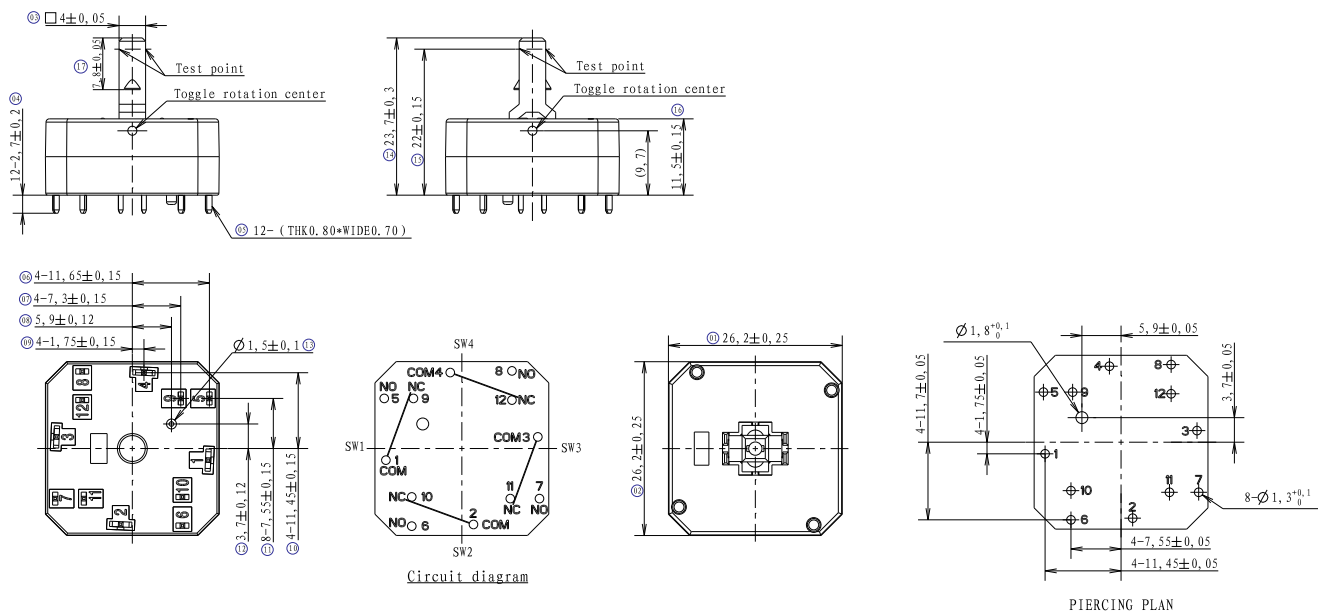

Dimensions are shown: mm
Specifications and dimensions subject to change