

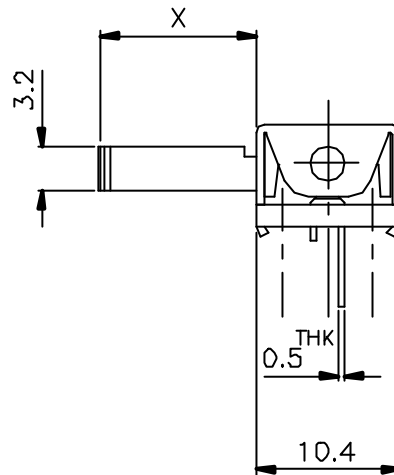

(NON-SHORTING)
SCHEMATIC

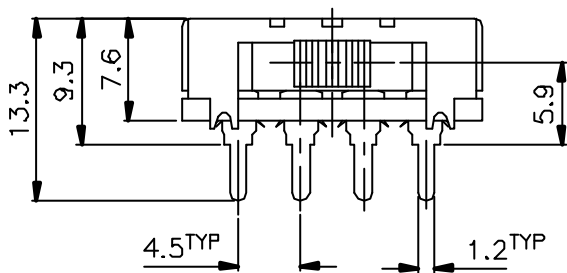
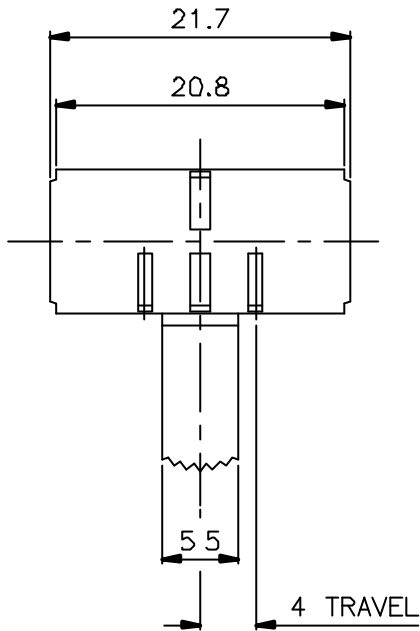

X=

ISSUED	SPECIFICATION (INITIAL)	TITLE: SLIDE SWITCH 1P3T		
	RATING: AC 125V 3A	MODEL NO: WK-13H10-G		
	CONTACT RESISTANCE: MAX. 30mΩ	UNIT: m m	DWN	
	INSULATION RESISTANCE: 500MΩ AT 500V DC	SCALE: 2 : 1	CHK'D	
	WITHSTAND VOLTAGE: AC 1000V FOR 1 MIN	TOLERANCE: ±0.20	APPD.	
	OPERATION FORCE: 300 ± 100 g			
	SWITCHING LIFE: 10,000 Cycles(6-10c/m loading)			
BY:	 广东科斯达电子科技有限公司 GUANG DONG KE SI DA ELECTRONIC TECHNOLOGY CO., LTD.	DRWG NO:		
DATE:		990054-01		