

**KSD**

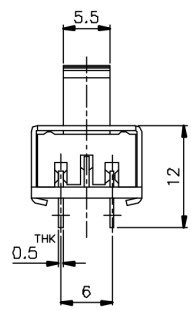
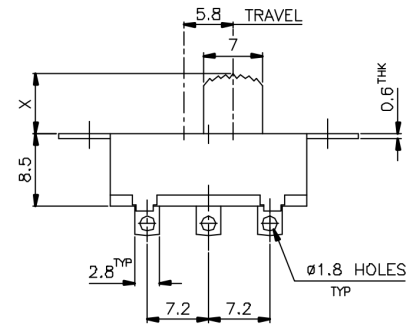
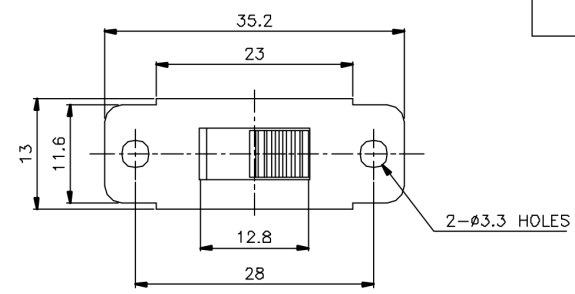
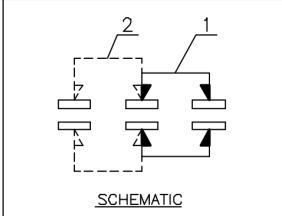

X=

ISSUED	SPECIFICATION (INITIAL)	TITLE: SLIDE SWITCH 2P2T	
	RATING: 3A 6A 125V 250V AC	MODEL NO:	SS-22L07-G
	CONTACT RESISTANCE: Not more than 30mΩ	UNIT:	mm DWN
	INSULATION RESISTANCE: 500MΩ at 500V DC	SCALE:	2 : 1 CHK'D
	WITHSTAND VOLTAGE: AC 500V for 1 min	TOLERANCE:	±0.2 APPD.
	OPERATION FORCE: 450±150g		
	SWITCHING LIFE: 100000Cycles(6-10c/m loading)		
BY:	<b>广东科斯达电子科技有限公司</b> GUANG DONG KE SI DA ELECTRONIC TECHNOLOGY CO., LTD.	DRWG NO:	810001-00
DATE:			