

# KSD

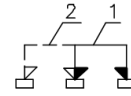

Non-shorting  
SCHEMATIC

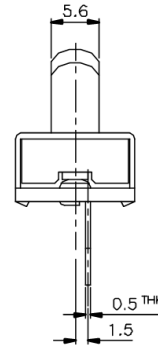
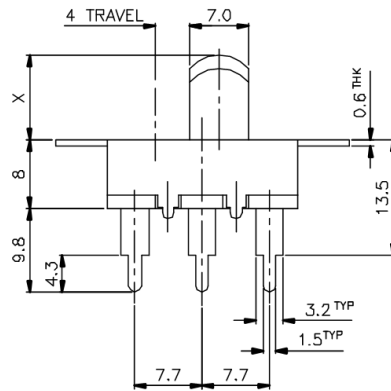
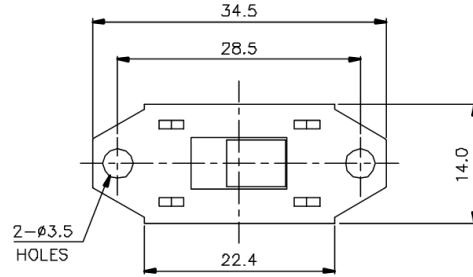

MARKING: SIDE A: **KSD** 0505

X=

SIDE B: AC 125V 6A

ISSUED	SPECIFICATION (INITIAL)	TITLE: SLIDE SWITCH 1P2T
	RATING: AC 125V 6A	MODEL NO: CL04-SS12H02-G(H1)
	CONTACT RESISTANCE: Not more than 30mΩ	UNIT: m m DWN
	INSULATION RESISTANCE: 500MΩ AT 500V DC	SCALE: 2 : 1 CHK'D
	WITHSTAND VOLTAGE: AC 1000V FOR 1 MIN	TOLERANCE: ±0.20 APPD.
	OPERATION FORCE: 400 ± 200g	
	SWITCHING LIFE: 10,000 Cycles (6-10c/m loading)	
BY:	<b>广东科斯达电子科技有限公司</b> GUANG DONG KE SI DA ELECTRONIC TECHNOLOGY CO., LTD.	DRWG NO:
DATE:		870209-03