

KSD

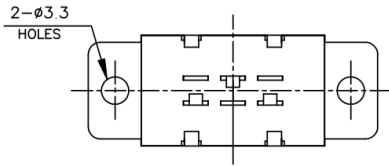
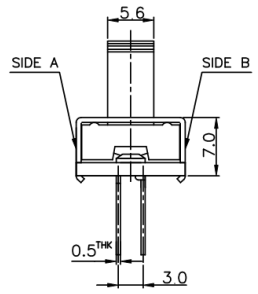
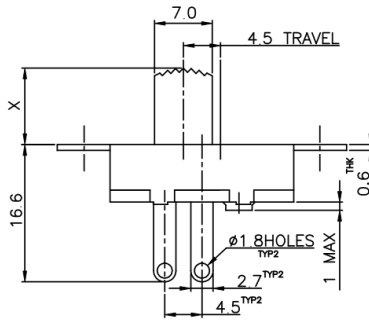
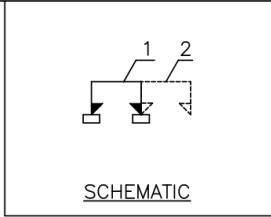
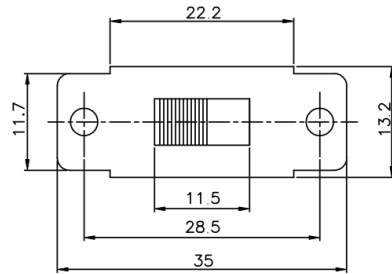

X =

MARKING:

SIDE A: **KSD**

SIDE B: U4 AC 125V 4A
AC 250V 2A

ISSUED	SPECIFICATION	TITLE: SLIDE SWITCH 1P2T			
	RATING: AC 125V 4A 250V 2A	MODEL NO: U4SS-12J17-G			
	CONTACT RESISTANCE: MAX. 30mΩ	UNIT: m	m	DWN	
	INSULATION RESISTANCE: 500MΩ at 500V DC	SCALE: 2 : 1	CHK'D		
	WITHSTAND VOLTAGE: AC 1000V for 1 min	TOLERANCE: ±0.20	APPD.		
	OPERATION FORCE: 300±100g				
	SWITCHING LIFE: 10000 Cycles(6-10c/m loading)				
BY:	广东科斯达电子科技有限公司 GUANG DONG KE SI DA ELECTRONIC TECHNOLOGY CO., LTD.	DRWG NO.	REV.		
DATE:		950411-02	A		