

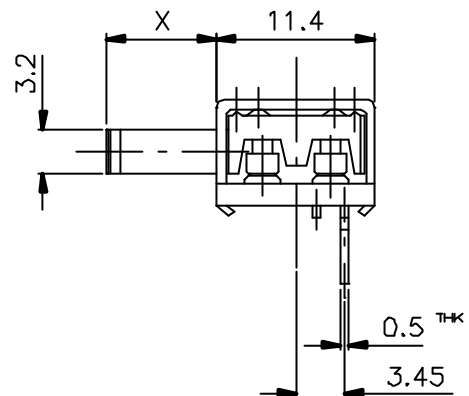

NON-SHORTING
SCHEMATIC

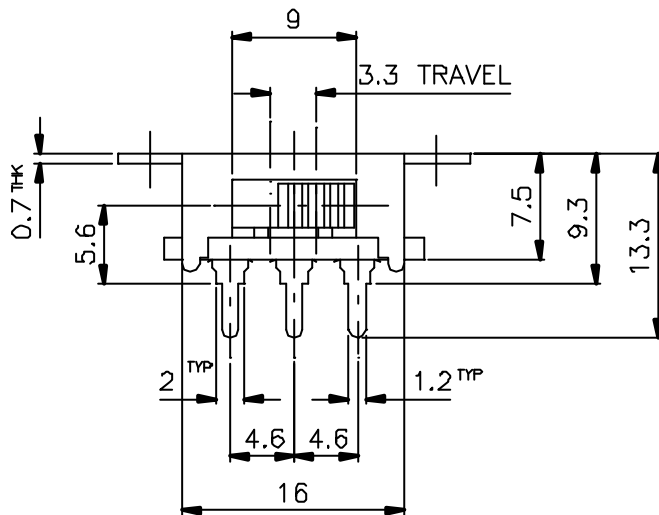
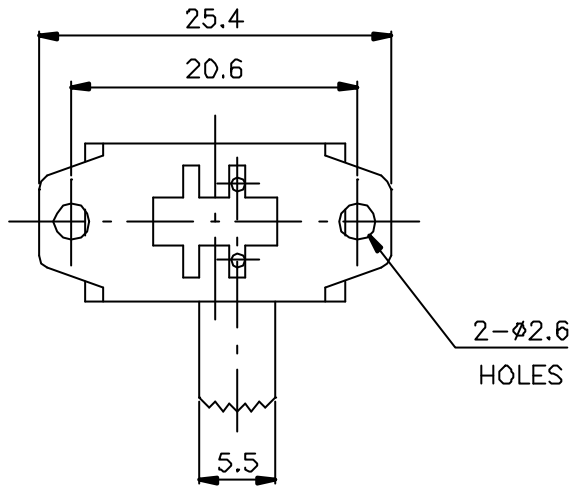

X=

ISSUED	SPECIFICATION (INITIAL)	TITLE:	SLIDE SWITCH 1P2T		
	RATING: AC 125V 3A	MODEL NO:	WK-12F25-G		
	CONTACT RESISTANCE: Not more than 30mΩ	UNIT: mm	DWN		
	INSULATION RESISTANCE: 500MΩ at 500V DC	SCALE: 2 1	CHK'D		
	WITHSTAND VOLTAGE: AC 1000V for 1 min	TOLERANCE: ±0.2	APPD.		
	OPERATION FORCE: 300±200g				
	SWITCHING LIFE: 10,000 Cycles(6-10c/m loading)				
BY:	 广东科斯达电子科技有限公司 GUANG DONG KE SI DA ELECTRONIC TECHNOLOGY CO., LTD.	DRWG NO:	991277-00		
DATE:					