

KSD

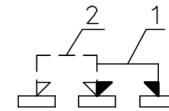

SHORTING SCHEMATIC

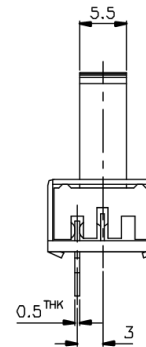
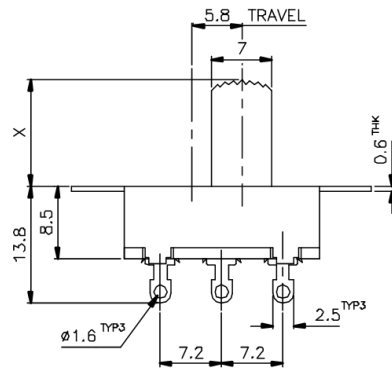
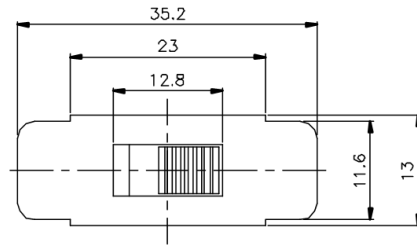

X=

ISSUED	SPECIFICATION (INITIAL)	TITLE: SLIDE SWITCH 1P2T
	RATING: 3A 6A 125V 250V AC	MODEL NO: SS-12L07-G-#205
	CONTACT RESISTANCE: Not more than 30mΩ	UNIT: mm DWN
	INSULATION RESISTANCE: 500MΩ at 500V DC	SCALE: 2 : 1 CHK'D
	WITHSTAND VOLTAGE: AC 500V for 1 min	TOLERANCE: ±0.2 APPD.
	OPERATION FORCE: 450 ± 150g	
	SWITCHING LIFE: 100000Cycles(6-10c/m loading)	
BY:	广东科斯达电子科技有限公司 GUANG DONG KE SI DA ELECTRONIC TECHNOLOGY CO., LTD.	DRWG NO:
DATE:		920292-00