

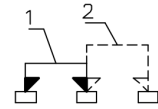

KSD

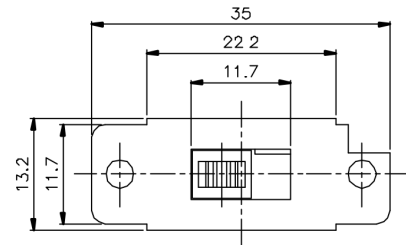

SCHEMATIC

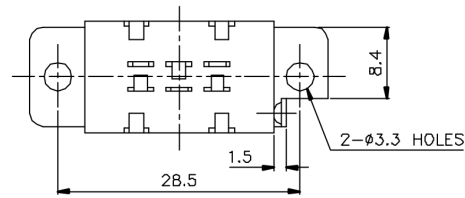
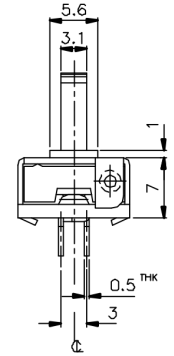
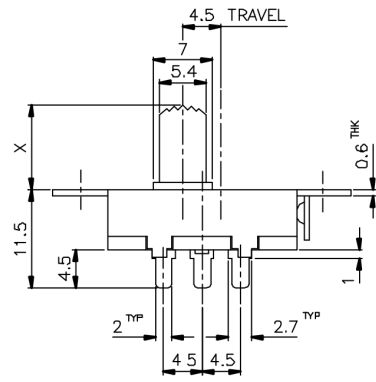

X=

ISSUED	SPECIFICATION (INITIAL)	TITLE: SLIDE SWITCH 1P2T
	RATING: 3A 6A 125V 250V AC	MODEL NO: SS-12J08-C(1)
	CONTACT RESISTANCE: Not more than 30mΩ	UNIT: m m DWN
	INSULATION RESISTANCE: 500MΩ AT 500V DC	SCALE: 2 : 1 CHK'D
	WITHSTAND VOLTAGE: AC 500V FOR 1 MIN	TOLERANCE: ±0.20 APPD.
	OPERATION FORCE: 300 ± 100g	
	SWITCHING LIFE: 10000 Cycles (6-10c/m loading)	
BY:	 广东科斯达电子科技有限公司 GUANG DONG KE SI DA ELECTRONIC TECHNOLOGY CO., LTD.	DRWG NO:
DATE:		850281-01