

KSD

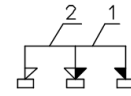

NON-SHORTING SCHEMATIC

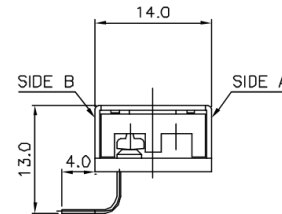
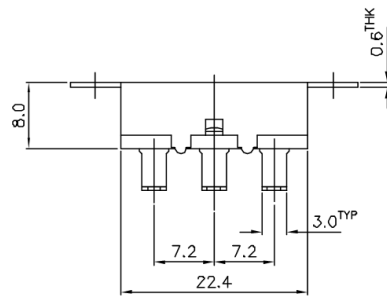
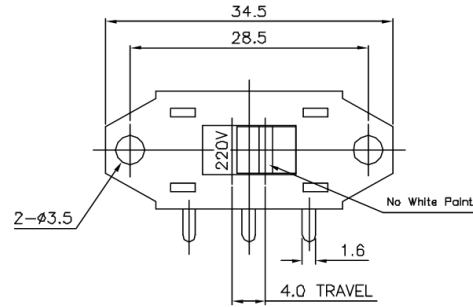

MARKING:

SIDE A: **KSD** **US**

SIDE B: U11 AC 125V 11A
AC 250V 5.5A

ISSUED	SPECIFICATION (INITIAL)	TITLE: SLIDE SWITCH 1P2T
	RATING: AC 125V 11A AC 250V 5.5A	MODEL NO: U11SS-12P02-G(C)0-#372
	CONTACT RESISTANCE: MAX. 30mΩ	UNIT: m m DWN Q F L 13.07.06
	INSULATION RESISTANCE: 500MΩ AT 500V DC	SCALE: 2 : 1 CHK'D
	WITHSTAND VOLTAGE: AC 1000V FOR 1 MIN	TOLERANCE: ±0.20 APPD.
	OPERATION FORCE: 400 ± 200 g	
	SWITCHING LIFE: 10000 Cycles(6-10c/m loading)	
BY:	广东科斯达电子科技有限公司 GUANG DONG KE SI DA ELECTRONIC TECHNOLOGY CO., LTD.	DRWG NO:
DATE:		A60426-00