

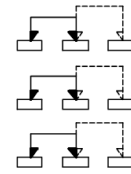

# KSD

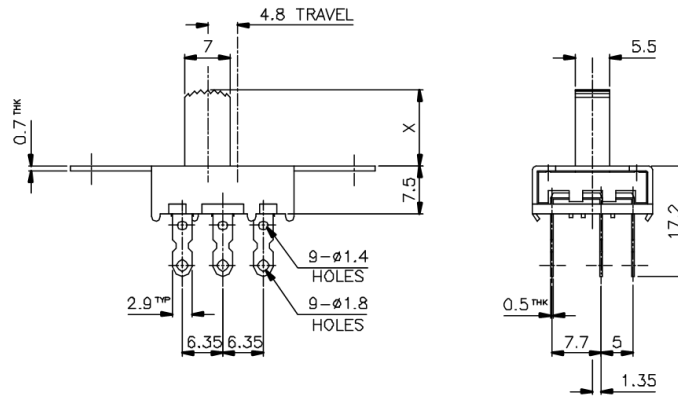

NON-SHORTING SCHEMATIC

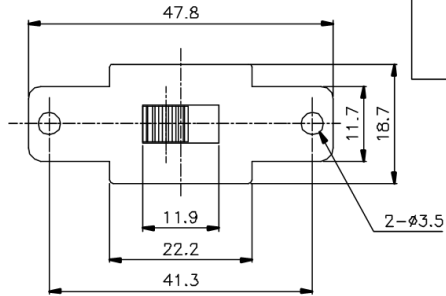

X=

ISSUED	SPECIFICATION (INITIAL)	TITLE: SLIDE SWITCH 3P2T
	RATING: AC 125V 3A	MODEL NO: WS-32J01-G
	CONTACT RESISTANCE: Not more than 30mΩ	UNIT: mm DWN
	INSULATION RESISTANCE: 500MΩ at 500V DC	SCALE: 1.5 : 1CHK'd
	WITHSTAND VOLTAGE: AC 1000V for 1 min	TOLERANCE: ±0.2PPD.
	OPERATION FORCE: 500±150g	
	SWITCHING LIFE: 10,000Cycles(6-10c/m loading)	
BY:	 广东科斯达电子科技有限公司	DRWG NO: 890133-00
DATE:	GUANG DONG KE SI DA ELECTRONIC TECHNOLOGY CO., LTD.	