

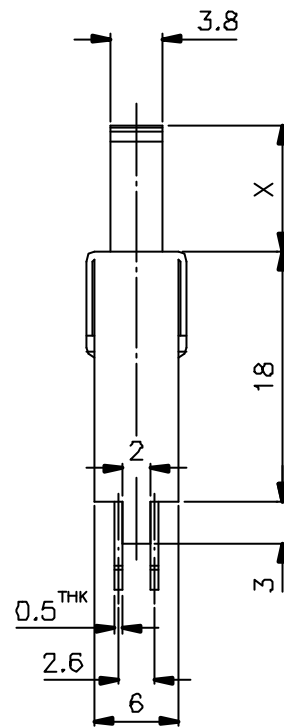

SCHEMATIC

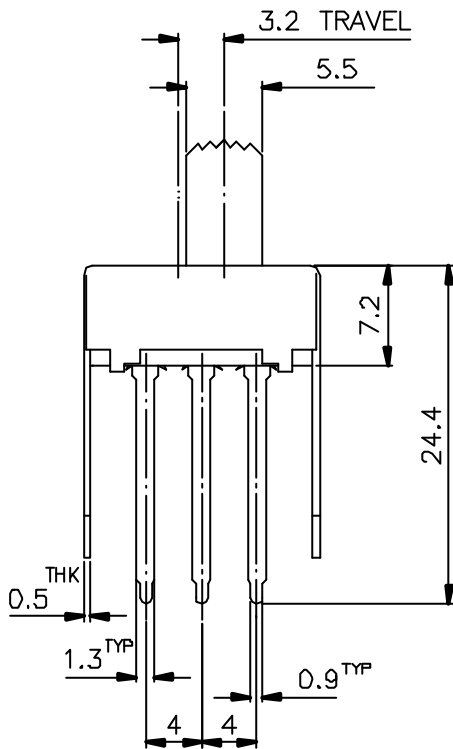
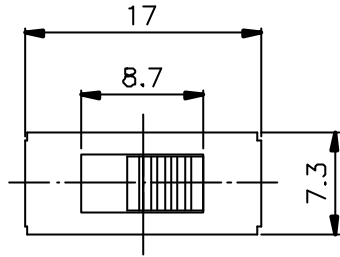

X=

ISSUED	SPECIFICATION (INITIAL)	TITLE: SLIDE SWITCH 2P2T			
	RATING: DC 50V 0.5A	MODEL NO: SS-22F21-G			
	CONTACT RESISTANCE: Not more than 30mΩ	UNIT: mm	DWN	X.J.Mo	22/4/97
	INSULATION RESISTANCE: 500MΩ at 500V DC	SCALE: 2 : 1	CHK'D		
	WITHSTAND VOLTAGE: AC 500V for 1 min	TOLERANCE: ±0.2	APPD.		
	OPERATION FORCE: 400 ± 250g				
	SWITCHING LIFE: 10000 cycles(6-10C/M loading)				
BY	 广东科斯达电子科技有限公司 GUANG DONG KE SI DA ELECTRONIC TECHNOLOGY CO., LTD.	DRWG NO:			
DATE:		B800978-01			