

KSD

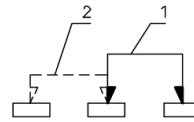

SCHEMATIC

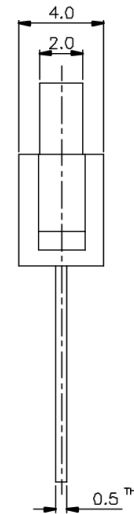
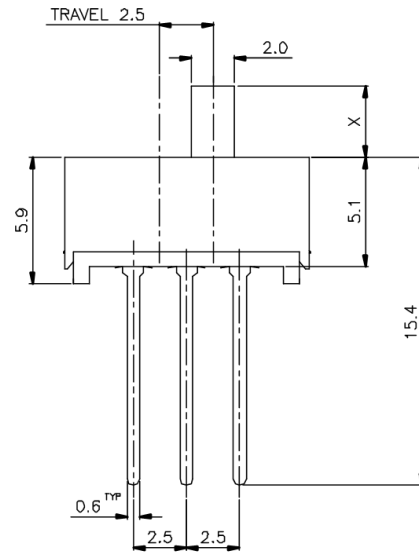
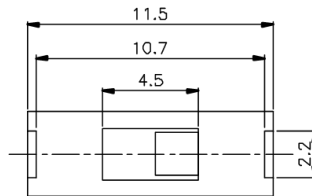

X=

NOTE:
SOLDER TEMPERATURE
NOT TO EXCEED 230°C
5 SEC (MAX)

ISSUED	SPECIFICATION (INITIAL)	TITLE: SLIDE SWITCH 1P2T
	RATING: DC 50V 0.5A	MODEL NO: SS-12E03-G(B)
	CONTACT RESISTANCE: Not more than 30mΩ	UNIT: m m DWN
	INSULATION RESISTANCE: 500MΩ at 500V DC	SCALE: 5 : 1 CHK'D
	WITHSTAND VOLTAGE: AC 500V for 1 min	TOLERANCE: ±D 2 APPD.
	OPERATION FORCE: 200±150g	
	SWITCHING LIFE: 10000cycles(6-10c/m loading)	
BY:	广东科斯达电子科技有限公司 GUANG DONG KE SI DA ELECTRONIC TECHNOLOGY CO., LTD.	DRWG NO:
DATE:		860334-01