

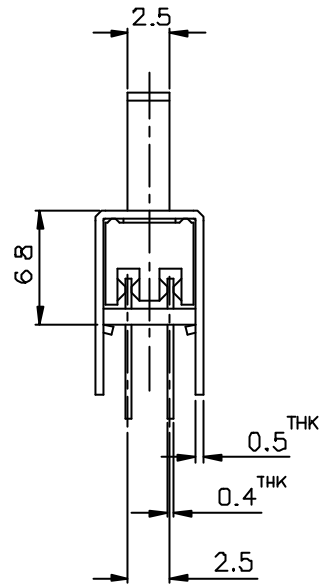

SCHEMATIC

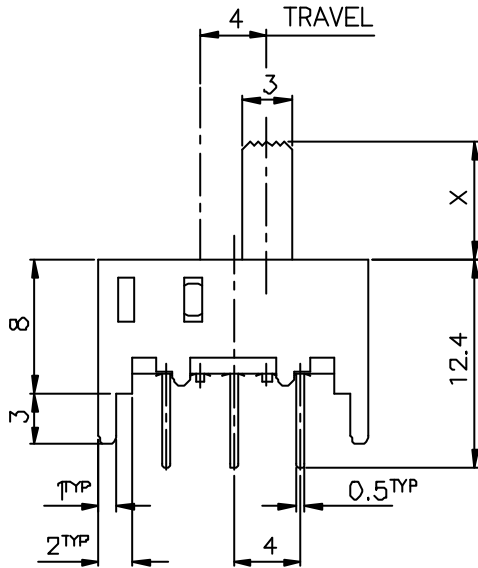
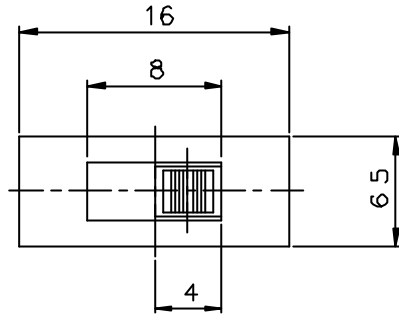

X=

ISSUED	SPECIFICATION (INITIAL)	TITLE: SLIDE SWITCH 2P2T			
	RATING: DC 50V 0.5A	MODEL NO: SS-22H08-G(A)			
	CONTACT RESISTANCE: Not more than 30mΩ	UNIT: mm	DWN	YANG	13/9/04
	INSULATION RESISTANCE: 500MΩ at 500V DC	SCALE 2.5 : 1	CHK'D		
	WITHSTAND VOLTAGE: AC 500V for 1 min	TOLERANCE: ±0.2	APPD.		
	OPERATION FORCE: 200 ± 100g				
	SWITCHING LIFE: 10000 Cycles(6-10c/m loading)				
EY:	 <b>广东科斯达电子科技有限公司</b> GUANG DONG KE SI DA ELECTRONIC TECHNOLOGY CO., LTD.	DRWG NO:			
DATE		A40622-00			