

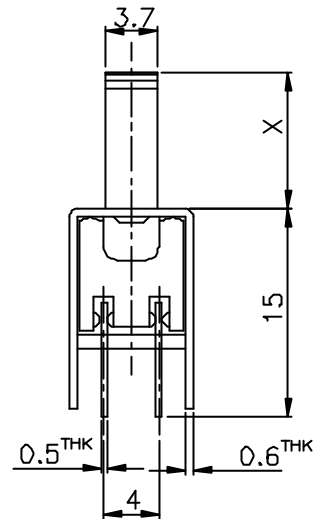

SCHEMATIC

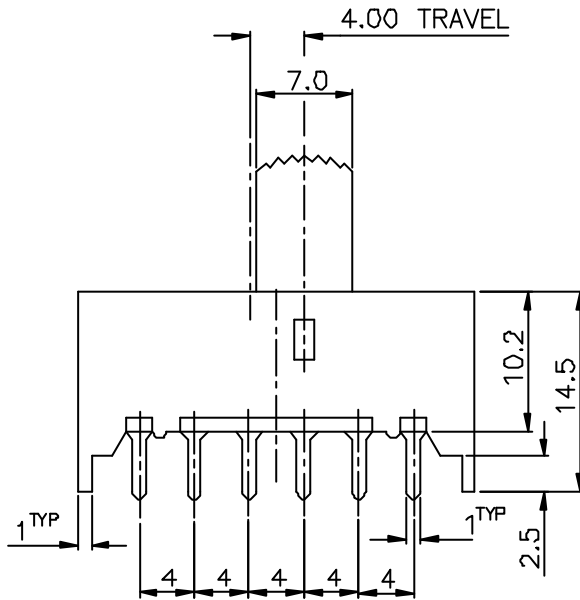
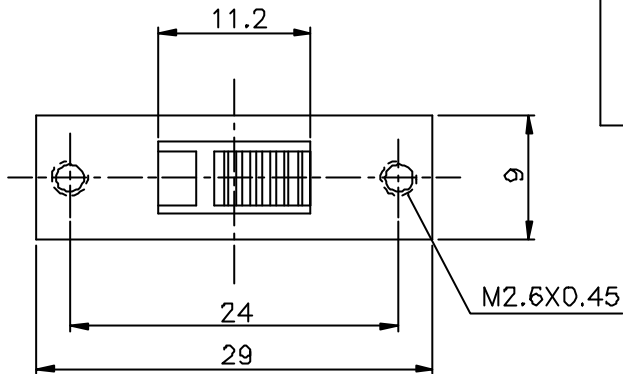

X =

ISSUED	SPECIFICATION {INITIAL}	TITLE: SLIDE SWITCH 4P2T			
	RATING: DC 50V 0.5A	MODEL NO: SS-42H06-G			
	CONTACT RESISTANCE: MAX.30m Ω	UNIT: m m	DWN	FANG	11/4/97
	INSULATION RESISTANCE: 500MΩ AT 500V DC	SCALE: 2 : 1	CHK'D		
	WITHSTAND VOLTAGE: AC 500V FOR 1 MIN	TOLERANCE: ±0.2	APPD.		
	OPERATION FORCE: 450 ± 250 g				
	SWITCHING LIFE: 10000 Cycles(6-10c/m loading)				
BY:	 广东科斯达电子科技有限公司 GUANG DONG KE SI DA ELECTRONIC TECHNOLOGY CO., LTD.	DRWG NO:			
DATE:		B 800803-00			