

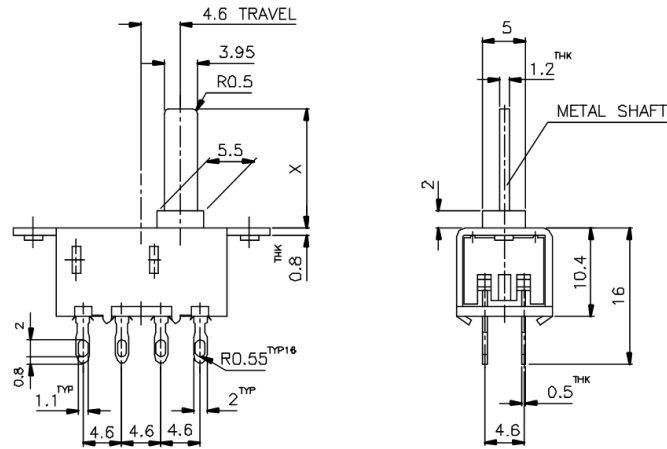

# KSD

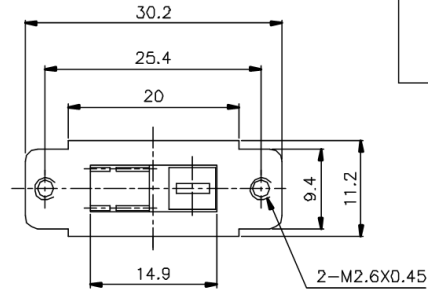
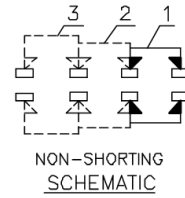

X =

ISSUED	SPECIFICATION (INITIAL)	TITLE:	SLIDE SWITCH 2P3T	
	RATING: AC 125V 0.5A	MODEL NO:	WS-23103-M	
	CONTACT RESISTANCE: Not more than 30mΩ	UNIT:	mm	DWN
	INSULATION RESISTANCE: 500MΩ at 500V DC	SCALE:	2 : 1	CHK'D
	WITHSTAND VOLTAGE: AC 1000V for 1 min	TOLERANCE:	±0.20	APPD.
	OPERATION FORCE: 500±300g			
	SWITCHING LIFE: 10000 Cycles (6-10c/m loading)			
BY:	 <b>广东科斯达电子科技有限公司</b> GUANG DONG KE SI DA ELECTRONIC TECHNOLOGY CO., LTD.	DRWG NO:	890138-00	
DATE:				