

# KSD

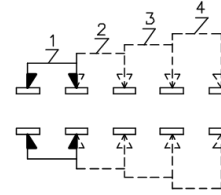

NON-SHORTING  
SCHEMATIC

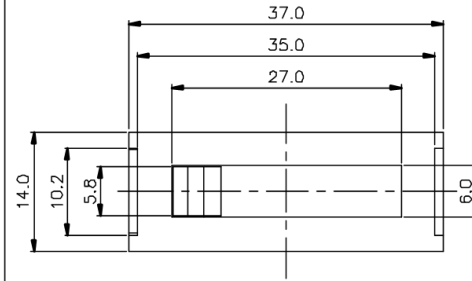
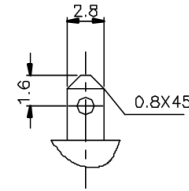
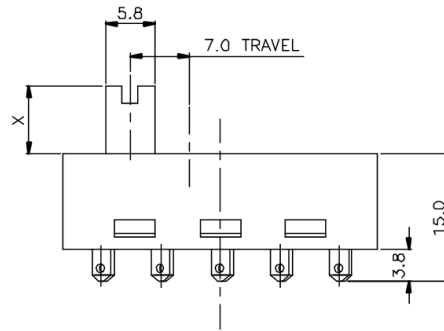

A DETAIL  
SCALE 4:1

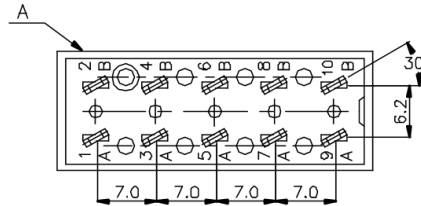

MARKING: U16SS **KSD**

10(1)A 250V~T85  $\mu$

ISSUED	SPECIFICATION (INITIAL)	TITLE: SLIDE SWITCH 2P4T
	RATING: 10(1)A 250V ~	MODEL NO: U16SS-24N01-G(C)
	CONTACT RESISTANCE: Not more than 30m $\Omega$	UNIT: $\square\square$ DWN
	INSULATION RESISTANCE: 500M $\Omega$ at 500V DC	SCALE: 2 : 1 CHK'D
	WITHSTAND VOLTAGE: AC 1000V for 1 min	TOLERANCE: $\pm 0.20$ APPD.
	OPERATION FORCE: 500 $\pm$ 200g	
	SWITCHING LIFE: 10,000 Cycles(6-10c/m loading)	
BY:	广东科斯达电子科技有限公司 GUANG DONG KE SI DA ELECTRONIC TECHNOLOGY CO., LTD.	DRWG NO:
DATE:		