

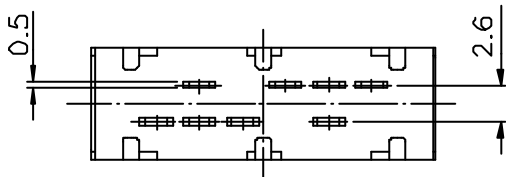

SCHEMATIC

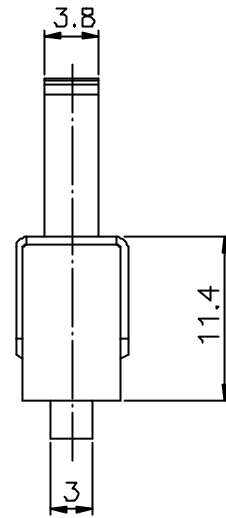
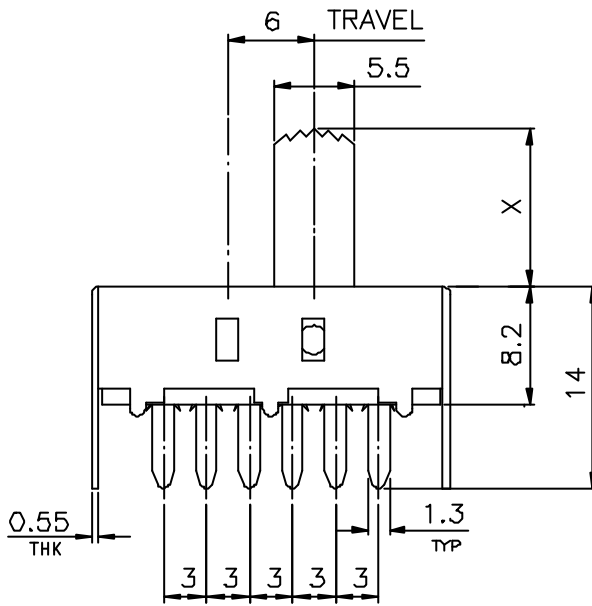

X=

ISSUED	SPECIFICATION (INITIAL)	TITLE: SLIDE SWITCH 2P2T			
	RATING: DC 50V 0.5A	MODEL NO: SS-22L12-G			
	CONTACT RESISTANCE: Not more than 30mΩ	UNIT: m m	DWN	XZK	11.09.09
	INSULATION RESISTANCE: 500MΩ at 500V DC	SCALE: 2 : 1		CHK'D	
	WITHSTAND VOLTAGE: AC 500V for 1 min	TOLERANCE: ±0.2		APPD.	
	OPERATION FORCE: 400 ± 200g				
	SWITCHING LIFE: 10000 Cycles(6-10c/m loading)				
BY:	 广东科斯达电子科技有限公司 GUANG DONG KE SI DA ELECTRONIC TECHNOLOGY CO., LTD.	DRWG NO:		REV:	
		A90440-00		A	