

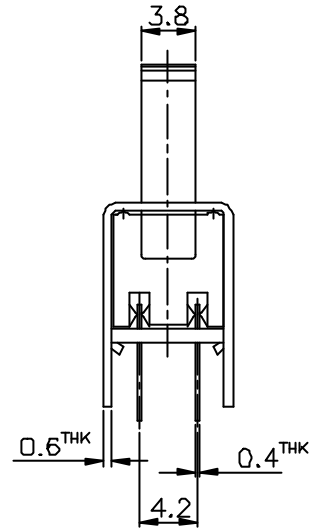

SCHEMATIC

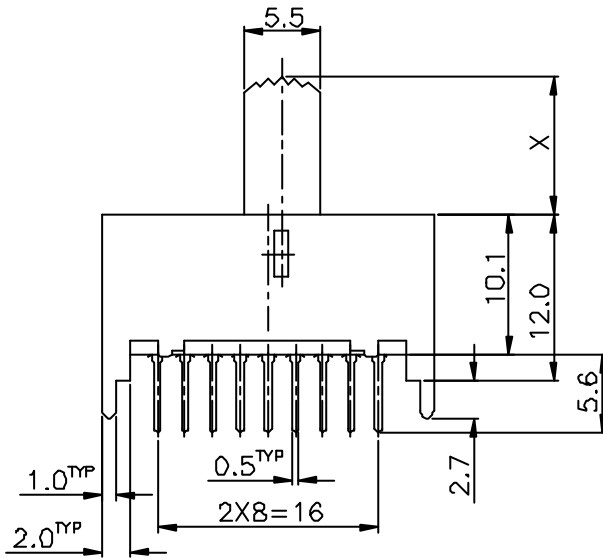

X =

ISSUED	SPECIFICATION (INITIAL)	TITLE: SLIDE SWITCH 6P2T			
	RATING: DC 50V 0.5A	MODEL NO: SS-62D01-G			
	CONTACT RESISTANCE MAX. 30mΩ	UNIT: m	m	DWN	TSANG
	INSULATION RESISTANCE: 500MΩ at 500V DC	SCALE: 2 : 1	CHK'D		
	WITHSTAND VOLTAGE: AC 500V for 1 min	TOLERANCE: ±0.2	APPD.		
	OPERATION FORCE: 350 ± 150 g				
	SWITCHING LIFE: 10000 Cycles (6-10c/m loading)				
BY:	 <b>广东科斯达电子科技有限公司</b> GUANG DONG KE SI DA ELECTRONIC TECHNOLOGY CO., LTD.	DRWG NO:			
DATE:		830179-00			