

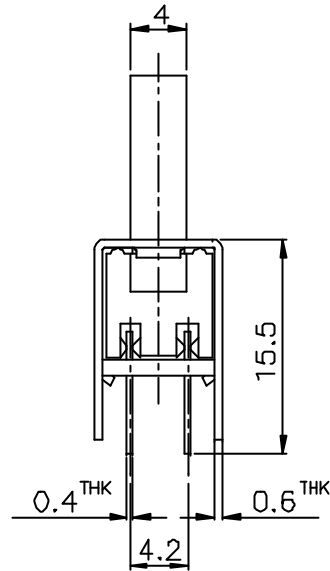

SCHMATIC

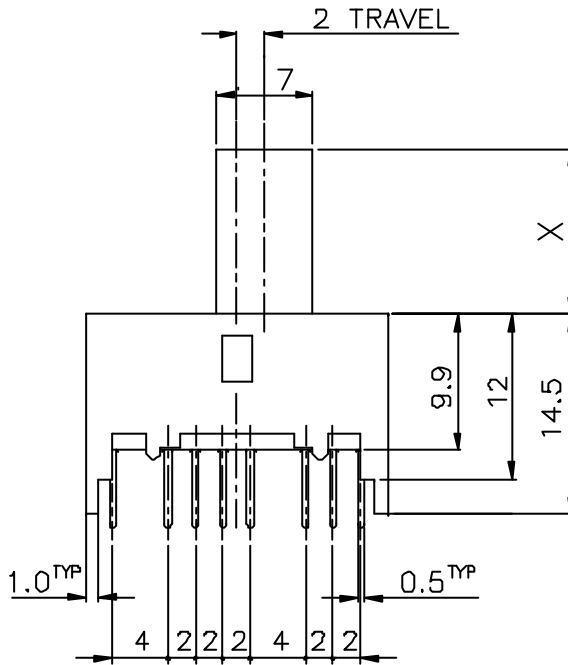
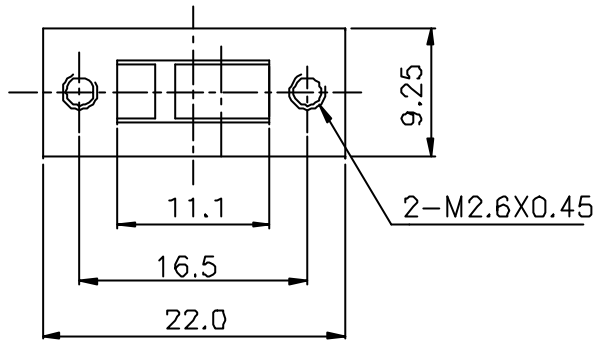

X=

ISSUED	SPECIFICATION (INITIAL)	TITLE: SLIDE SWITCH 4P3T			
	RATING: DC 50V 0.5A	MODEL NO: SS-43D01-G(B)			
	CONTACT RESISTANCE: Not more than 30mΩ	UNIT: m m	DWN	TSANG	25.10.88
	INSULATION RESISTANCE: 500MΩ at 500V DC	SCALE: 2 : 1	CHK'D		
	WITHSTAND VOLTAGE: AC 500V for 1 min	TOLERANCE: ±0.2	APPD.		
	OPERATION FORCE: 400±250g				
	SWITCHING LIFE: 10000 Cycles(6-10c/m loading)				
BY:	 广东科斯达电子科技有限公司 GUANG DONG KE SI DA ELECTRONIC TECHNOLOGY CO., LTD.	DRWG NO:			
DATE:		880332-01			